

TC-500A

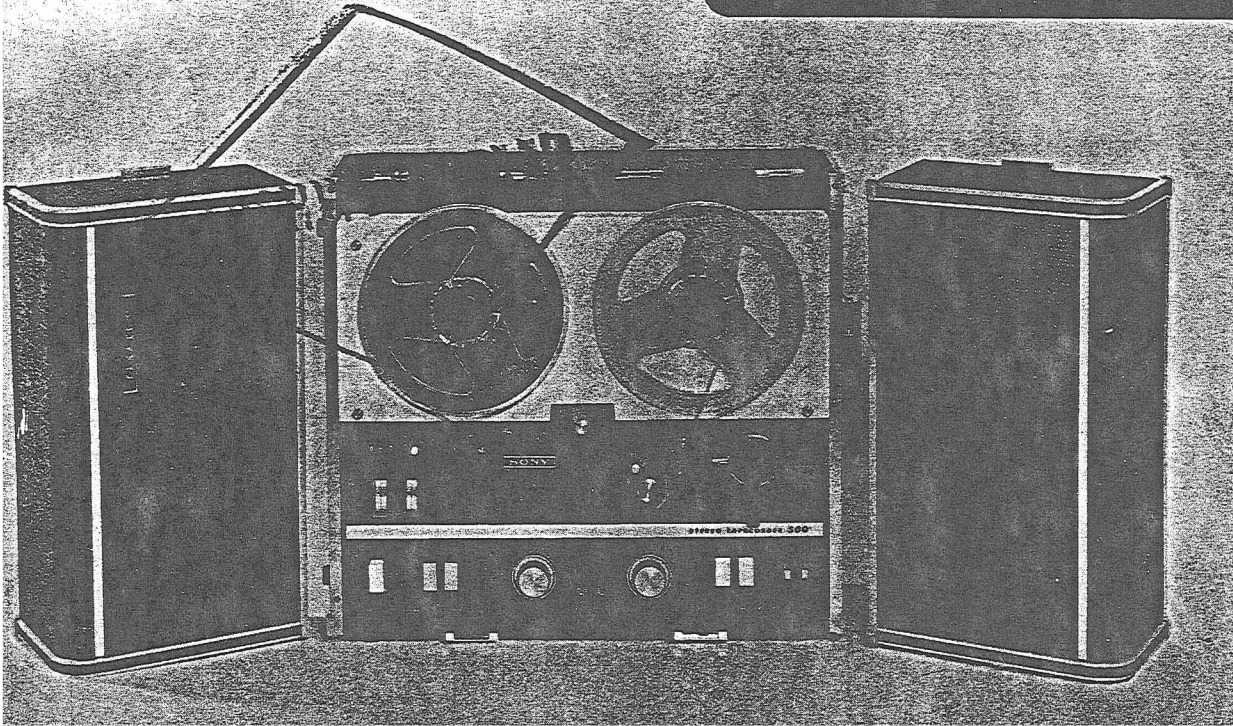

Specifications

- Power Requirement:** 110 Watts
100V, 110V, 117V, 125V, 220V or 240V (Voltage selector provided in the set)
AC 50 c/s or 60 c/s (Convertible by changing Capstan, Pinch Roller and Frequency Switch)
- Tape Speeds:** Instantaneous selection, 7-1/2 ips or 3-3/4 ips (19 or 9.5 cm/s)
- Track System:** 4-Track
- Reel Size:** Up to 7" (18 cm)
- Frequency Response:** 30~18,000 cps at 7-1/2 ips (19 cm/sec)
30~13,000 cps at 3-3/4 ips (9.5 cm/sec)
- Signal-to-Noise Ratio:** 50 dB (Measured by NAB standards)
(Per Channel)
- Flutter and Wow:** Less than 0.15% at 7-1/2 ips
Less than 0.20% at 3-3/4 ips
- Bias Frequency:** Approx. 80 Kc
- Level Indication:** Two VU Meters (calibrated to 0 dB at 12dB below saturation)
- Input Circuit:** 2-Microphone Jack (high impedance)
2-Auxiliary Input Jack (high impedance)
- Output Circuit:** 2-Monitor Speaker Jack (low impedance)
2-Line Output Jack (1.5 K Ω -0 dB)
1-Bi-aural Monitor Jack (low impedance)
- Output Level:** Monitor Speaker (3 watts per channel)
- Tube Complement:** 2-12AD7 (or 12AX7), 2-6AU6, 2-6AQ5, 1-12BH7A, 1-6CA4
- Weight:** Approx. 55 lbs. (25 Kg)
- Dimensions:** 18-1/2 W x 16-3/16 D x 12-1/4 H"
(470 W x 410 D x 310 H mm)

SONY®
SERVICING GUIDE

Removal of Reel Panel

- 1) Remove 5 phillips head screws and chrome cup washers, being careful not to loosen plastic washers from decorative metal washers.
- 2) Lift panel from recorder.

Removal of Control Panel

- 1) Remove speakers.
- 2) Remove fuse and cap.
- 3) Place recorder face down on padded surface.
- 4) Remove 2 machine screws and washers under handle.
- 5) Remove 4 screws and washers from back of case.
- 6) The chassis can be removed from case.

Removal of Chassis from Cabinet

- 1) Remove head cover.
- 2) Remove speed selector knob.
- 3) Remove plastic cap from instant stop lever.
- 4) Remove function selector knob.
- 5) Remove MIC/play knobs—by pulling off.
- 6) Remove auxiliary knobs—by loosening set screw.
- 7) Remove phillips screw and washer under head cover and both tape guides.
- 8) Remove electronics bottom cover ; loosen 3 oval head phillips screws on rear of chassis ; cover will then slip out.
- 9) Remove 3 phillips head screws and washers—located just under lip of electronics chassis.
- 10) Lift control panel from recorder.

Alignment Procedure

The alignment is to be performed at a tape speed of 7-1/2 ips unless otherwise specified. Connect an 8 ohm load resistor in parallel with the VTVM terminals and connect the VTVM to the Speaker Output Jack (J₁₀₄ and/or J₂₀₄). Set the Speaker ON/OFF Switch on.

1. Azimuth Alignment of the Playback Head

- 1) Align the upper edges of the Erase Head Core and Rec/PB Head Core and upper edge of Tape by turning the two Tape Guides located near the Heads. (H10 in Fig. 6)
- 2) Play back a 10 kc signal recorded on the first section of the SONY alignment tape "N-19-F1".
- 3) Adjust the azimuth alignment screw located on the right side of the Playback Head to obtain the maximum reading on the VTVM.
- 4) Perform the procedure 1) again.
- 5) Turn the Tape Guide (H10 L) clockwise by 30 degrees and the Tape Guide (H10 R) counter-clockwise by 30 degrees.
- 6) Perform the procedure 3) again.

2. Adjustment of Maximum Output

- 1) Turn the MIC/Playback Level Control R_{114} (R_{214}) (shown in Fig. 4) clockwise to the full.
- 2) Set the Bass Boost Switch off
- 3) Play back the 700 c/s signal recorded on the third section of the Alignment Tape "N-19-F1".
- 4) Adjust the Potentiometer R_{126} (R_{226}) (shown in Fig. 2) so that the VTVM indicates 4.47 V (2.5 W).

3. Adjustment of Frequency Response

- 1) Play back the 700 c/s signal recorded on the third section of the Alignment Tape "N-19-F1"
- 2) Turn the MIC/Playback Level Control R_{114} (R_{214}) (shown in Fig. 4) until the VTVM indicates 0 dBs (0.775 V).
- 3) Play back the 10 kc signal recorded on the 4th section of the Alignment Tape and adjust the Playback Equalizer R_{107} (R_{207}) (shown in Fig. 2) so that the VTVM reading is within ± 2 dB.

4. Adjustment of Hum Balancer

- 1) Play back the 700 c/s signal recorded at the standard recording level on the second section of the alignment tape "N-19-F1".
- 2) Adjust the MIC/Playback Level Control R_{114} (R_{214}) (shown in Fig. 4) so that the VTVM indicates 2.83 V (1 W).
- 3) Remove the Alignment Tape.
- 4) Press the Record Button and adjust the Hum Balancer R_7 (R_8) (shown in Fig. 3) for the minimum reading on the VTVM.
- 5) Set the machine in "PLAY" mode.
- 6) Adjust the Hum Bucking Coil L_{102} (L_{202}) (shown in Fig. 3) for the minimum reading on the VTVM.

5. Playback Level Adjustment

- 1) Set the Speaker ON/OFF Switch off. Connect a VTVM to the LINE OUT Jack.
- 2) Play back a 700 c/s signal recorded on the third section of the alignment tape "N-19-F1" and turn the MIC/Playback Level Control R_{114} (R_{214}) (shown in Fig. 4) until the VTVM reads 0 dBs (0.775 V).
- 3) Turn the Playback Level Control R_{135} (R_{235}) (shown in Fig. 2) until the VU Meter reads 0 VU.

6. Recording Bias Adjustment

- 1) Set the machine in record mode.
- 2) Connect a VTVM across winding of the Rec/PB Head of Channel 1 (Channel 2).
- 3) Adjust the Trimmer Capacitor C_2 (C_3) shown in Fig. 2 so that the VTVM indicates between 90 V and 100 V.

7. Recording Level Adjustment

- 1) Set the Speaker ON/OFF Switch off.
- 2) Thread the SONY Alignment Tape "N-19-F1" on the machine.
- 3) Play back the 700 c/s tone which is recorded on the second section of the Alignment Tape.
- 4) Turn the MIC/Playback Level Control R_{114} (R_{214}) (shown in Fig. 4) so that the VU Meter indicates 0 VU.
- 5) Replace the Alignment Tape with a new Tape.
- 6) Set the machine in record mode.
- 7) Feed a 1 kc signal of -10 dBs from "LINE INPUT" Jack and turn the Aux. Recording Level Control R_{101} (R_{201}) (shown in Fig. 4) so that the VU Meter indicates 0 VU when the recorded signal is played back.
- 8) Set the machine in record mode. Turn the Recording Level Control R_{136} (R_{236}) (shown in Fig. 2) until the VU Meter indicates 0 VU.

Quick Guide to Simple Servicing

Trouble	Possible Cause	Service
Pilot lights out, motor inoperative	Open AC circuit	Check AC line connection to wall or chassis, check fuse, check On/Off switch. Check automatic shut-off switch.
No sound in playback when meters indicate signal	Defective speaker cords	Check speaker, cords and plugs for short or open circuits. Check SPEAKER SWITCH.
No sound in playback and meters do not indicate signal	Defective tubes in pre-amplifiers, head leads disconnected, defective rectifier 6AC4 tube, or defective power amplifier tube 6AQ5	Check pre-amplifier tubes 12AD7 and check lead connections of heads and at plugs in chassis. Check 6CA4 rectifier tube and check 6AQ5 amplifier tube.
Poor volume or dull sound in playback, poor frequency response	Dirt on head tracks	Clean heads.
Excessive tape hiss	Magnetized heads	Demagnetize heads.
Flutter and wow	Dirt and grease on capstan or pinch roller, slipping tape	Clean capstan and roller, lubricate motor, tighten capstan screw.
Crackling noise during volume adjustments	Dirty or defective volume controls	Contact competent technician or service station.
Pre or post echoes on recorded tapes	Print-through effect due to exposure of tapes to heat or magnetic fields	NOTE: To prevent print through, store tapes in cool place. Remove from storage space when operating the recorder.
Operates in playback but not in record, no meter indication	Defective microphones or microphone leads or input	Check if the recorder is in record position, check movement of record/playback switch, check microphone jacks or aux. input jacks.
Previously recorded sounds in background of newly recorded tapes	Poor erasure, dirt on heads	Clean erase head, check oscillator tube (12BH7A).

Schematic Diagram

Fig. 1)

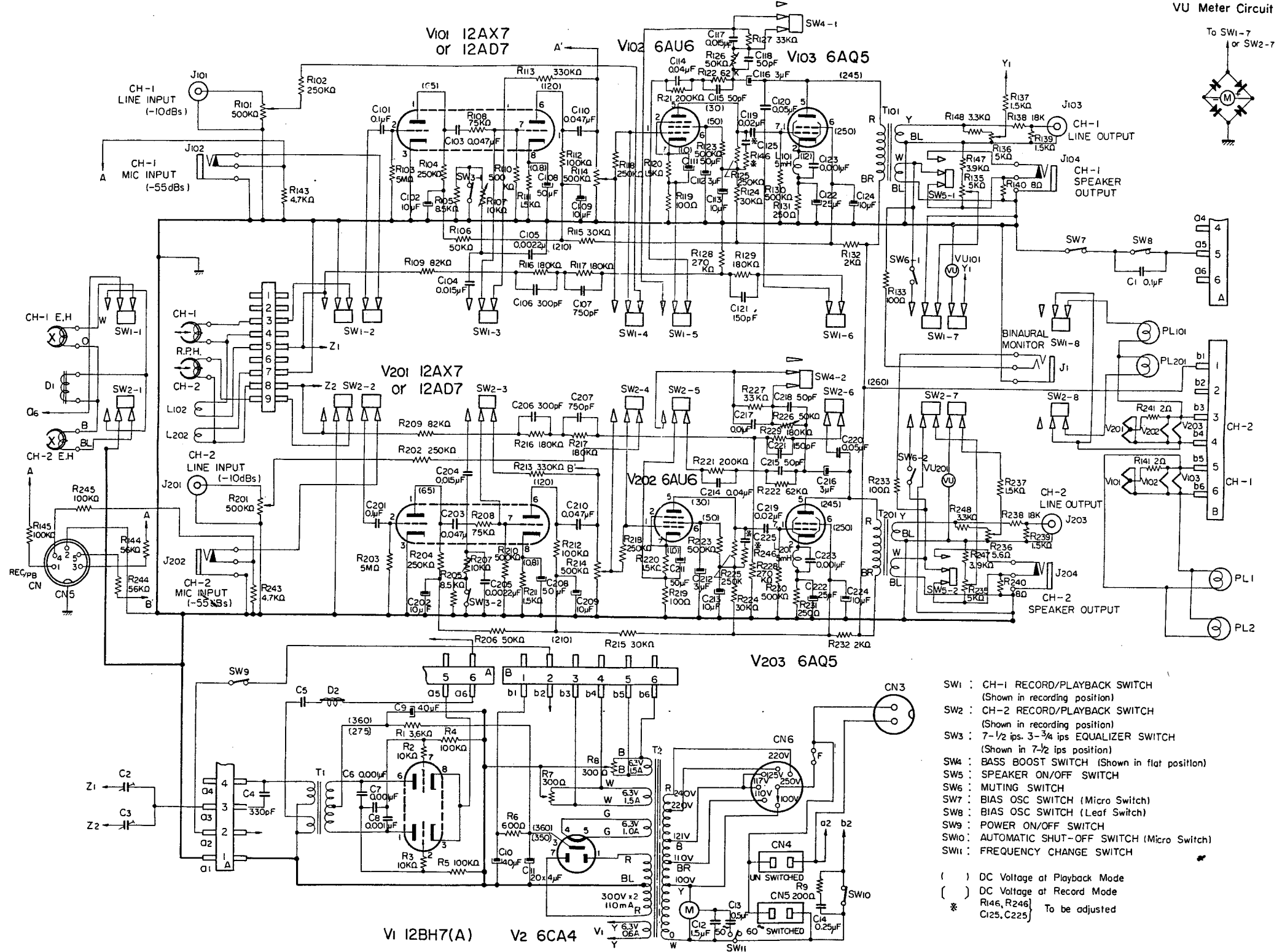

VU Meter Circuit

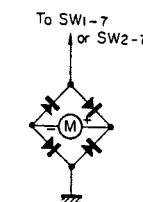

- SW1 : CH-1 RECORD/PLAYBACK SWITCH (Shown in recording position)
- SW2 : CH-2 RECORD/PLAYBACK SWITCH (Shown in recording position)
- SW3 : 7-1/2 ips. 3-3/4 ips EQUALIZER SWITCH (Shown in 7-1/2 ips position)
- SW4 : BASS BOOST SWITCH (Shown in flat position)
- SW5 : SPEAKER ON/OFF SWITCH
- SW6 : MUTING SWITCH
- SW7 : BIAS OSC SWITCH (Micro Switch)
- SW8 : BIAS OSC SWITCH (Leaf Switch)
- SW9 : POWER ON/OFF SWITCH
- SW10 : AUTOMATIC SHUT-OFF SWITCH (Micro Switch)
- SW11 : FREQUENCY CHANGE SWITCH

() DC Voltage at Playback Mode
 [] DC Voltage at Record Mode
 * R146, R246
 C125, C225 To be adjusted

Bottom View of Amplifier

(Fig. 2)

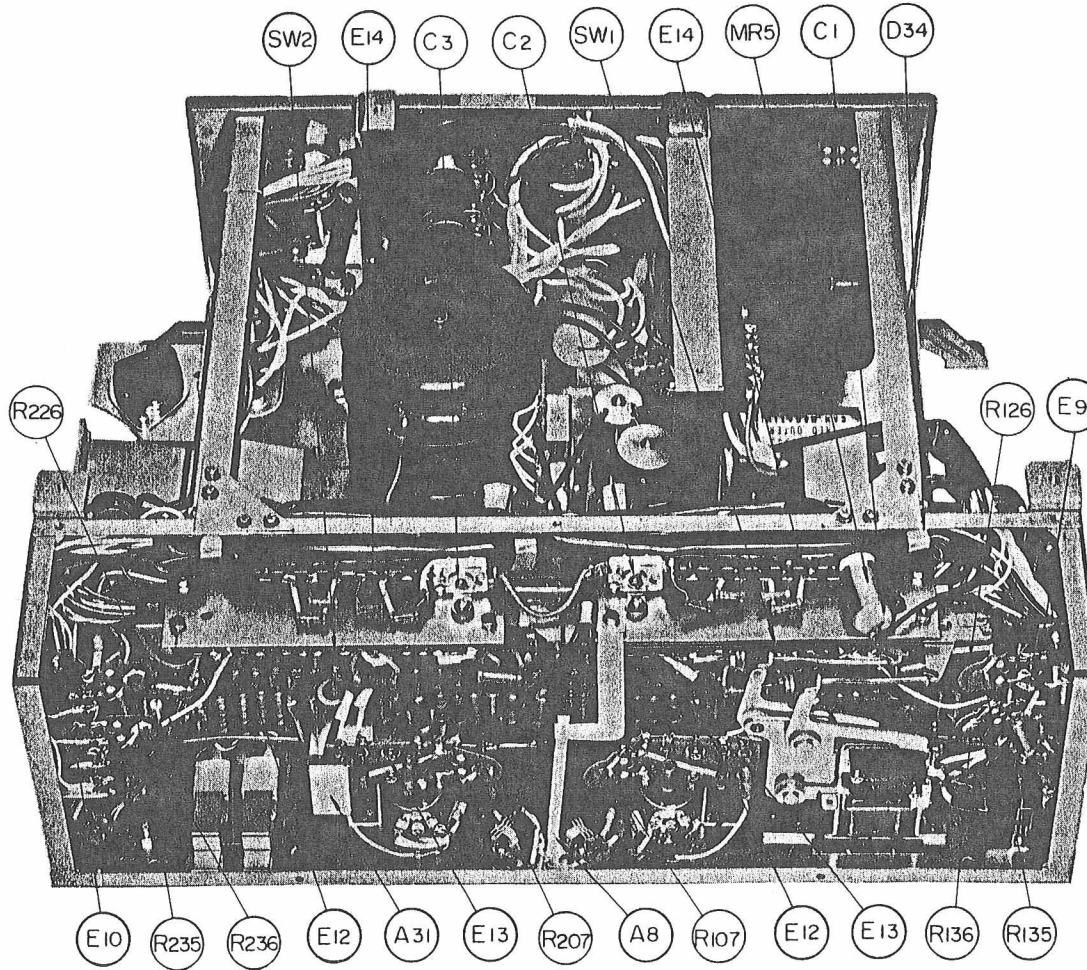

Location of Major Electrical Parts

(Fig. 3)

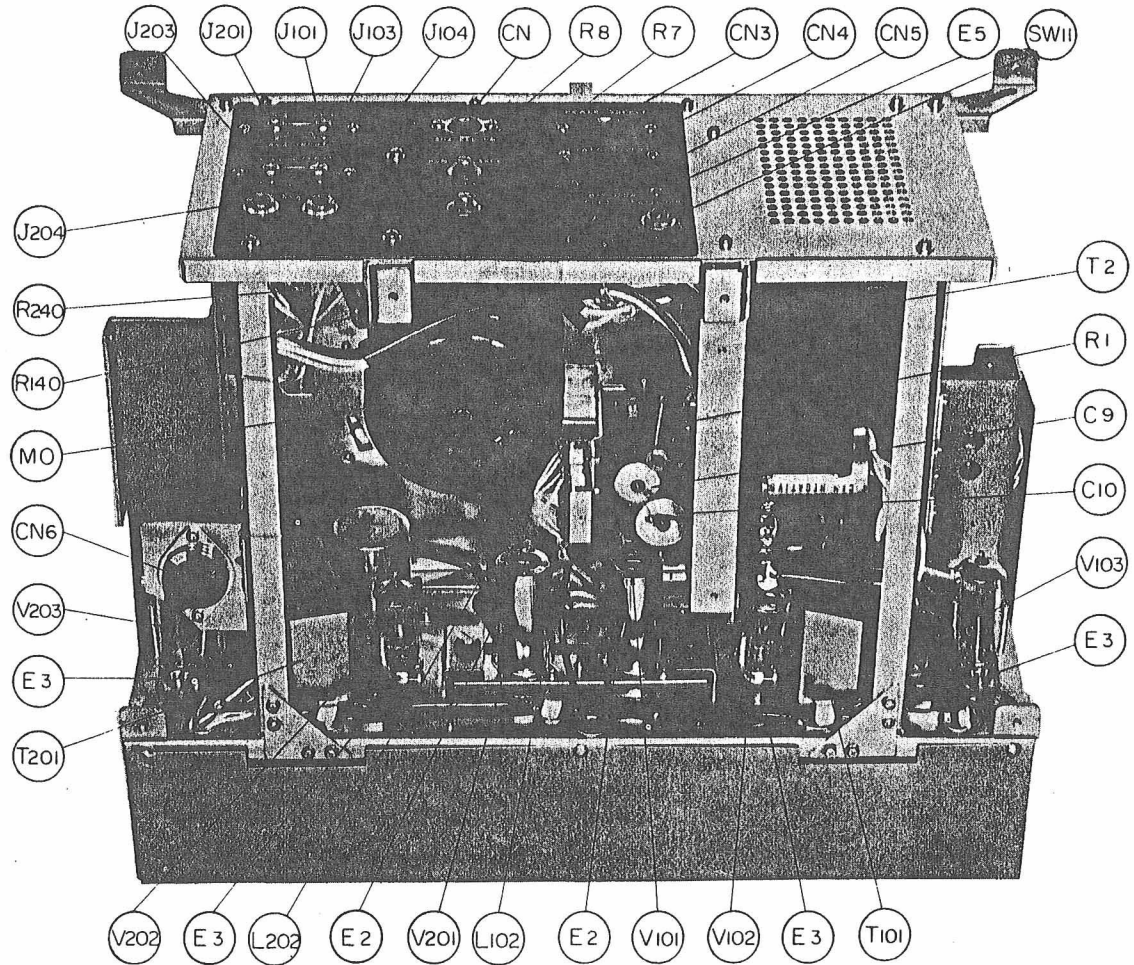

Tape Transport Mechanism

(Fig. 4)

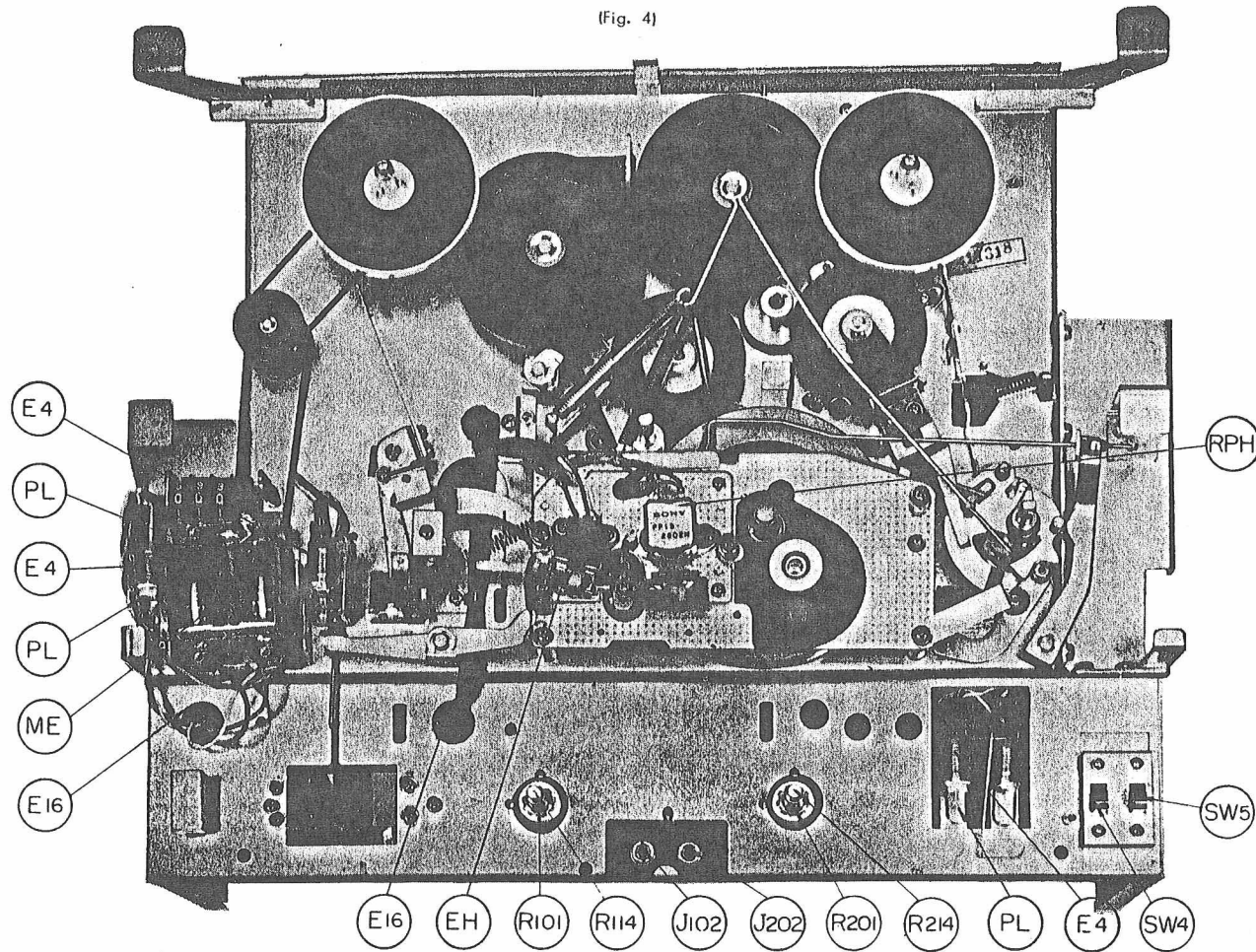

Parts List

Cabinet & Appearance Section

Symbol No.	Description	Q'ty	Symbol No.	Description	Q'ty
1	Cabinet Ass'y, including	1	13	Record Button Ass'y, including	2
1-1	Cabinet	(1)	13-1	Setting Screw	(2)
1-2	Cabinet Sash (A)	(2)	13-2	Nut for Setting Screw	(2)
1-3	" " (D)	(2)	14	Function Selector Knob Ass'y, including	1
1-4	Plastic Sash Cover (A)	(2)	14-1	Setting Screw	(1)
1-5	" " " (B)	(2)	15	Volume Control Knob (Upper) Ass'y, including	2
1-6	Grip Handle Ass'y	(1)	15-1	Setting Screw	(2)
1-7	Grip Handle Cover (Clear)	(1)	16	Volume Control Knob (Lower) Ass'y, including	2
1-8	Grip Handle Mounting Bracket	(2)	16-1	Face Plate	(2)
1-9	Screw Bolt for Grip Handle	(2)	16-2	Setting Screw	(2)
1-10	Rubber Handle Washer	(2)	17	Fast Forward Knob	1
1-11	Holding Plate for Grip Handle Bracket	(1)	18	Instant Stop Lever Knob	1
1-12	Ventilator Funnel	(1)	19	Spring for Fast Forward	1
1-13	Ventilator Grille	(1)	20	Spacer for Reel Mounting Screw	5
1-14	Lid for Connector Plate	(1)	21	Nylon Washer for Reel Panel Mount	5
1-15	Lock Metal for Connector Lid	(2)	22	Tension Lever Guide	2
1-16	Rubber Foot Stopper	(8)	23	Washer for Cabinet	6
1-17	Rubber Foot (Large)	(8)	24	Speaker Box Right (Cabinet Lid) Ass'y,	
1-18	" (Small)	(4)		including	1
1-19	Lid for AC Voltage Selector	(1)	24-1	Sash (B)	(1)
1-20	Reinforcing Plate for Cabinet	(4)	24-2	" (C)	(1)
1-21	Lock (Right)	(1)	24-3	" (D)	(2)
1-22	" (Left)	(1)	24-4	Plastic Sash Cover (A)	(2)
1-23	Speaker Box (Right)	(1)	24-5	" (B)	(2)
1-24	" (Left)	(1)	24-6	Baffle Board Holding Screw	(4)
2	Specification Label	1	24-7	Speaker Back Board	(1)
3	Escutcheon (Binaural Monitor)	1	24-8	Speaker Grille Metal	(1)
4	Escutcheon Holding Plate	1	24-9	Speaker Metallic Cover	(1)
5	Defeat Chain	1	24-10	Microphone Bag	(1)
6	Control Panel Ass'y, including	1	24-11	Stopper Washer for Rubber Foot	(2)
6-1	Control Panel	(1)	24-12	Cabinet Hinge	(2)
6-2	Lamp Cap	(2)	24-13	Speaker Holding Screw	(4)
6-3	Indicating Plate for Tape Speed	(1)	24-14	Rubber Foot	(2)
6-4	Ornamental Strip Holding Screw Post	(3)	24-15	Name Plate	(1)
6-5	Washer Ornamental Strip Holding Screw Post	(3)	25	Speaker Box Left (Cabinet Lid) Ass'y,	
6-6	Waseer for Ornamental Strip	(3)		including	1
6-7	Spacer for Lamp Cap	(2)	25-1	Sash (B)	(1)
6-8	Ornamental Strip	(1)	25-2	" (C)	(1)
7	Panel Spacer (Metal) for Control Panel	1	25-3	" (D)	(2)
8	Washer for Panel Spacer (Control Panel)	1	25-4	Plastic Sash Cover (A)	(2)
9	Reel Panel	1	25-5	" (B)	(2)
10	Head Cover Ass'y, including	1	25-6	Baffle Board Holding Screw	(4)
10-1	Name Plate "SONY"	(1)	25-7	Speaker Back Board	(1)
10-2	Head Cover Cushion	(1)	25-8	Speaker Grille Metal	(1)
10-3	Setting Screw	(2)	25-9	Speaker Metallic Cover	(1)
11	Speed Selector Knob Ass'y, including	1	25-10	Microphone Bag	(1)
11-1	Face Plate	(1)	25-11	Stopper Washer for Rubber Foot	(2)
11-2	Setting Screw	(1)	25-12	Cabinet Hinge	(2)
12	CN-OFF Push Button Ass'y, including	1	25-13	Speaker Holding Screw	(4)
12-1	Setting Screw	(1)	25-14	Rubber Foot	(2)
12-2	Nut for Setting Screw	(1)	26	Sash (E) for Speaker Box	2
			27	Speaker Cord Packing for Speaker Box	2

Head Deck and Capstan Fly Wheel Section

Symbol No.	Description	Q'ty	Symbol No.	Description	Q'ty
H1	Head Shield Plate for Erase Head	1	H6	Head Pad for Rec./P. B. Head. P-820-724	1
H2	Head Shield Plate for Rec./P. B. Head	1	H7	Head Deck Ass'y, including	1
H3	Head Pad for Erase Head	1	H7-1	Head Deck	(1)
H4	" "	1	H7-2	Felt Cushion	(1)
H5	Head Pad for Rec./P. B. Head	1	H7-3	Pinch Lever Shaft	(1)

Parts List

Symbol No.	Description	Q'ty	Symbol No.	Description	Q'ty
R106, 206	50 K Ω $\frac{1}{2}$ W Carbon	2	R147, 247	3.9 K Ω $\frac{1}{4}$ W Carbon	2
R107, 207	10 K Ω Semi-Fixed	2	R148, 248	3.3 K Ω " "	2
R108, 208	75 K Ω $\frac{1}{2}$ W Carbon	2		Capacitors	
R109, 209	82 K Ω $\frac{1}{4}$ W "	2	C1	0.1 μ F 400WV Oil Paper	1
R110, 210	500 K Ω $\frac{1}{2}$ W "	2	C2	30~200PF Trimmer Capacitor	1
R111, 211	1.5 K Ω " "	2	C3	30~200PF " "	1
R112, 212	100 K Ω " "	2	C4	330PF 1,000WV Mica	1
R113, 213	330 K Ω $\frac{1}{4}$ W "	2	C5	0.5 μ F 250WV MP (Tubular)	1
R114, 214	500 K Ω Aux. Input Level Control (Combined with R101 (201))	2	C6	0.001 μ F 400WV Mica	1
R115, 215	30 K Ω $\frac{1}{2}$ W Carbon	2	C7	0.001 μ F " "	1
R116, 216	180 K Ω $\frac{1}{4}$ W "	2	C8	0.001 μ F " "	1
R117, 217	180 K Ω " "	2	C9	40 μ F " Electrolytic (Tubular)	1
R118, 218	250 K Ω $\frac{1}{2}$ W "	2	C10	40 μ F 350WV " (")	1
R119, 219	100 Ω " "	2	C11	20 μ F \times 4 450WV "	1
R120, 220	1.5 K Ω " "	2	C12, 13	1.5 μ F+0.5 μ F MP	1
R121, 221	200 K Ω " "	2	C14	0.25 μ F 600WV Oil Paper	1
R122, 222	62 K Ω " "	2	C101, 201	0.1 μ F 100WV Mylar	2
R123, 223	500 K Ω " "	2	C102, 202	10 μ F 350WV Electrolytic	2
R124, 224	30 K Ω " "	2	C103, 203	0.047 μ F 200WV Mylar	2
R125, 225	250 K Ω " "	2	C104, 204	0.015 μ F 50WV "	2
R126, 226	50 K Ω Semi-Fixed	2	C105, 205	0.0022 μ F " "	2
R127, 227	33 K Ω $\frac{1}{4}$ W Carbon	2	C106, 206	300PF 250WV Polyethylene	2
R128, 228	270 K Ω " "	2	C107, 207	750PF " "	2
R129, 229	180 K Ω " "	2	C108, 208	50 μ F 6WV Electrolytic (Tubular)	2
R130, 230	500 K Ω $\frac{1}{2}$ W "	2	C109, 209	10 μ F 350WV "	2
R131, 231	250 Ω 2W "	2	C110, 210	0.047 μ F 200WV Mylar	2
R132, 232	2 K Ω $\frac{1}{4}$ W "	2	C111, 211	50 μ F 6WV Electrolytic (Tubular)	2
R133, 233	100 Ω $\frac{1}{4}$ W "	2	C112, 212	3 μ F 350WV "	2
R134, 234	—deleted—		C113, 213	10 μ F " "	2
R135, 235	5 K Ω Semi-Fixed	2	C114, 214	0.04 μ F 100WV Mylar	2
R136, 236	5 K Ω " "	2	C115, 215	50PF 250WV Polyethylene	2
R137, 237	1.5 K Ω $\frac{1}{2}$ W Carbon	2	C116, 216	3 μ F 350WV Electrolytic (Tubular)	2
R138, 238	18 K Ω " "	2	C117, 217	0.015 μ F 50WV Mylar	2
R139, 239	1.5 K Ω " "	2	C118, 218	50PF 250WV Polyethylene	2
R140, 240	8 Ω 2W "	2	C119, 219	0.02 μ F 100WV Mylar	2
R141, 241	2 Ω $\frac{1}{2}$ W Wire Wound	2	C120, 220	0.05 μ F 400WV Oil Paper	2
R142, 242	—deleted—		C121, 221	150PF 250WV Polyethylene	2
R143, 243	4.7 K Ω $\frac{1}{4}$ W Carbon	2	C122, 222	25 μ F 15WV Electrolytic	2
R144, 244	56 K Ω " "	2	C123, 223	0.001 μ F 100WV Mylar	2
R145, 245	100 K Ω " "	2	C124, 224	10 μ F 350WV Electrolytic	2
R146, 246	10 K Ω " "	2	C125, 225	200PF 250WV Polyethylene	2

Exploded Diagram

(Fig. 5)

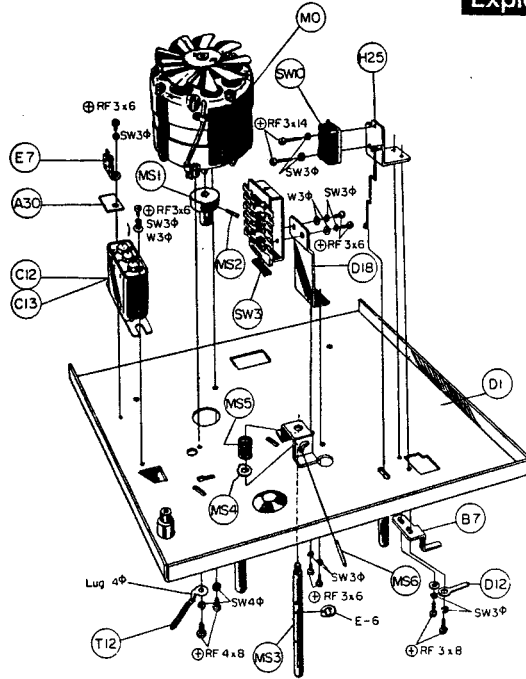

(Fig. 6)

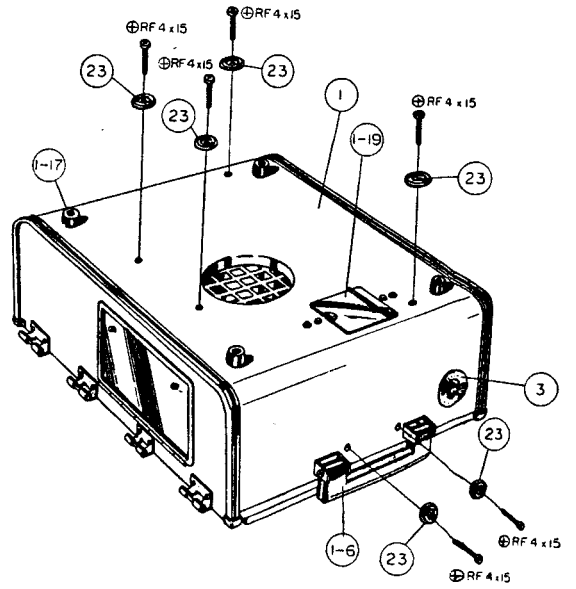

(Fig. 7)

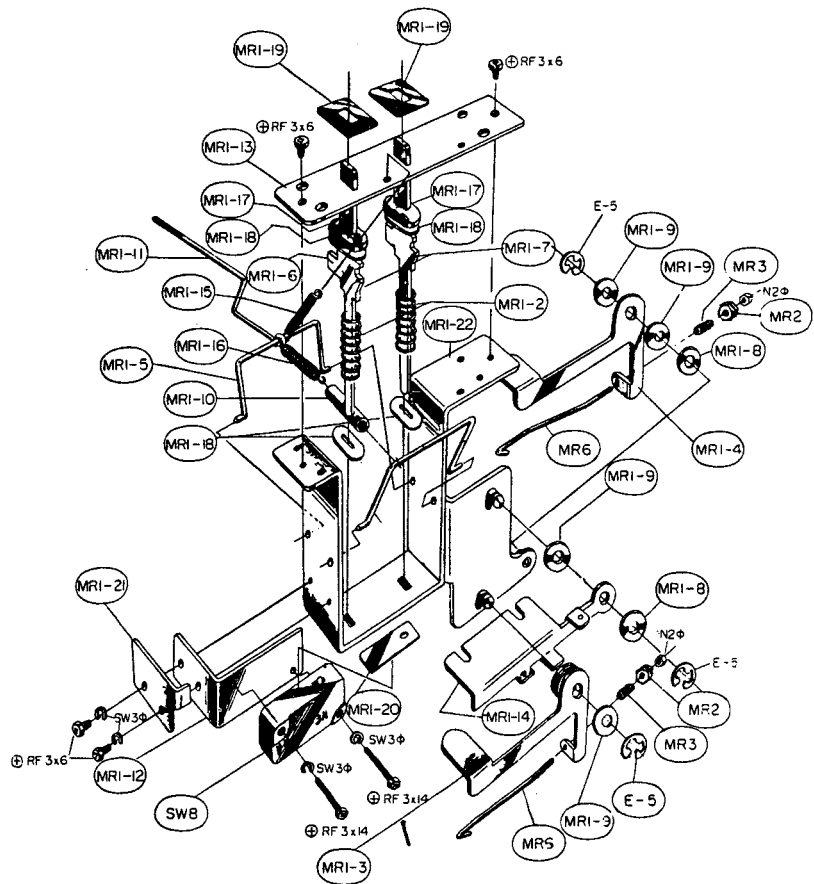

Exploded Diagram

(Fig. 8)

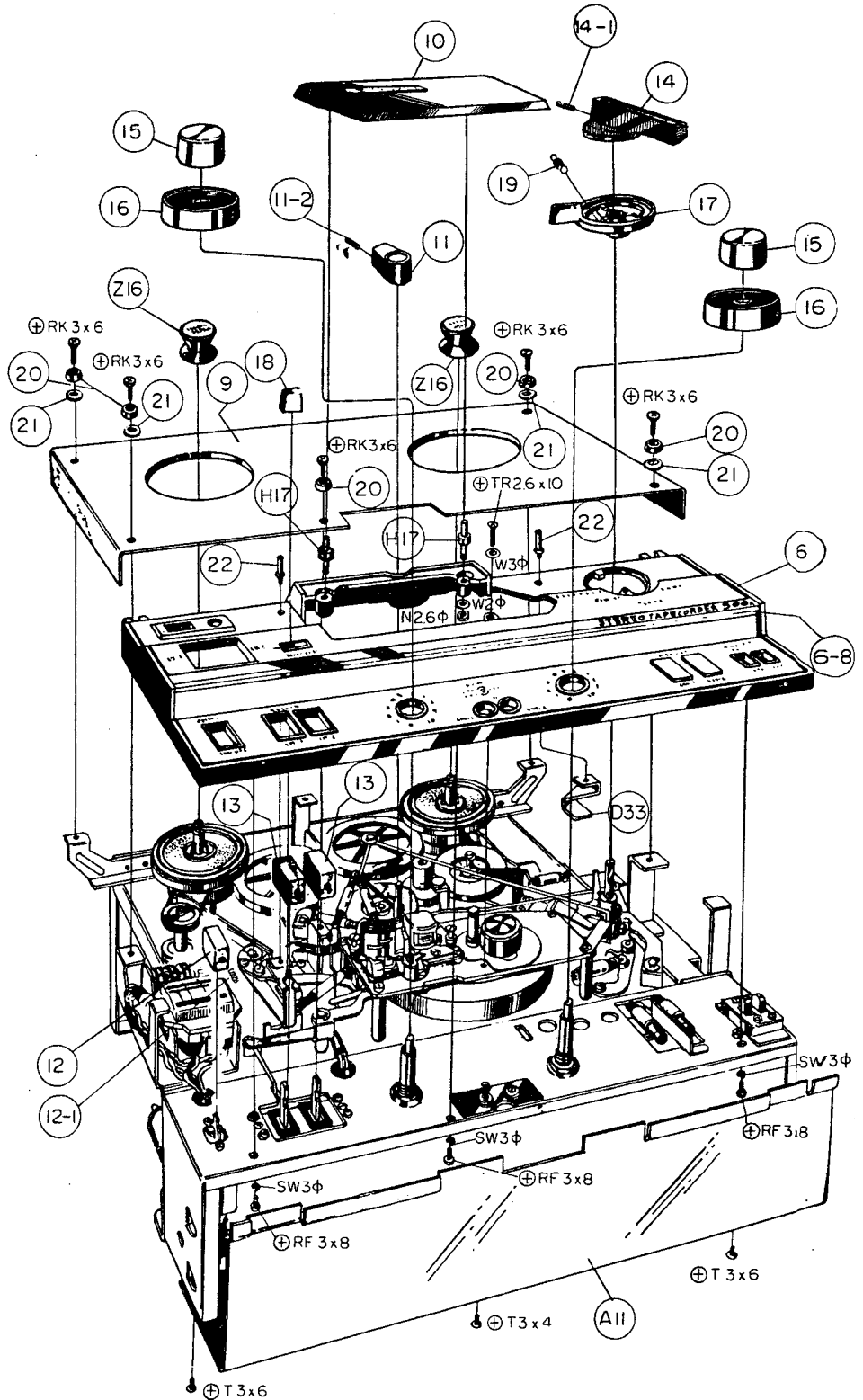

Exploded Diagram

(Fig. 9)

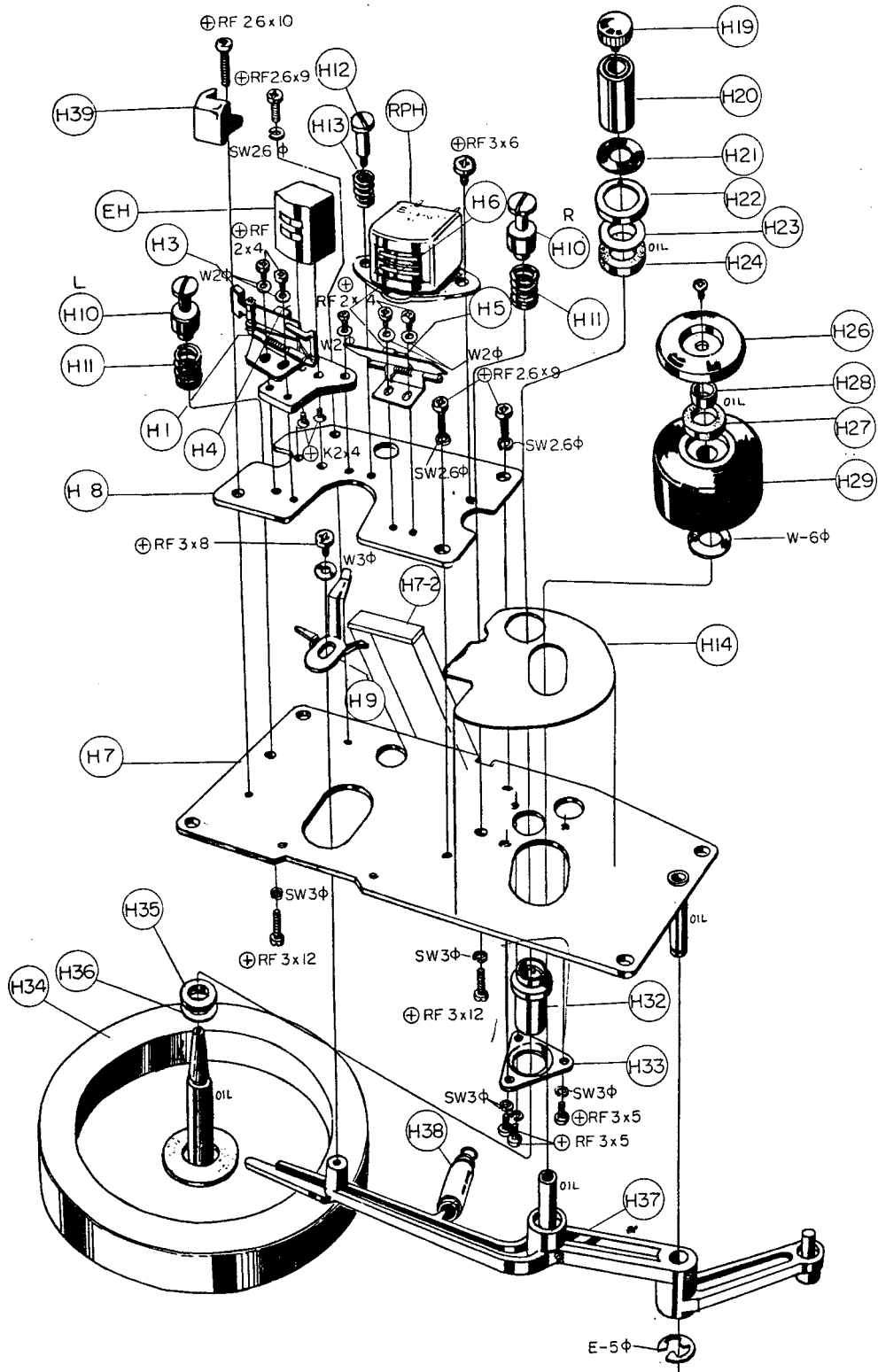

Exploded Diagram

Fig. 101

19

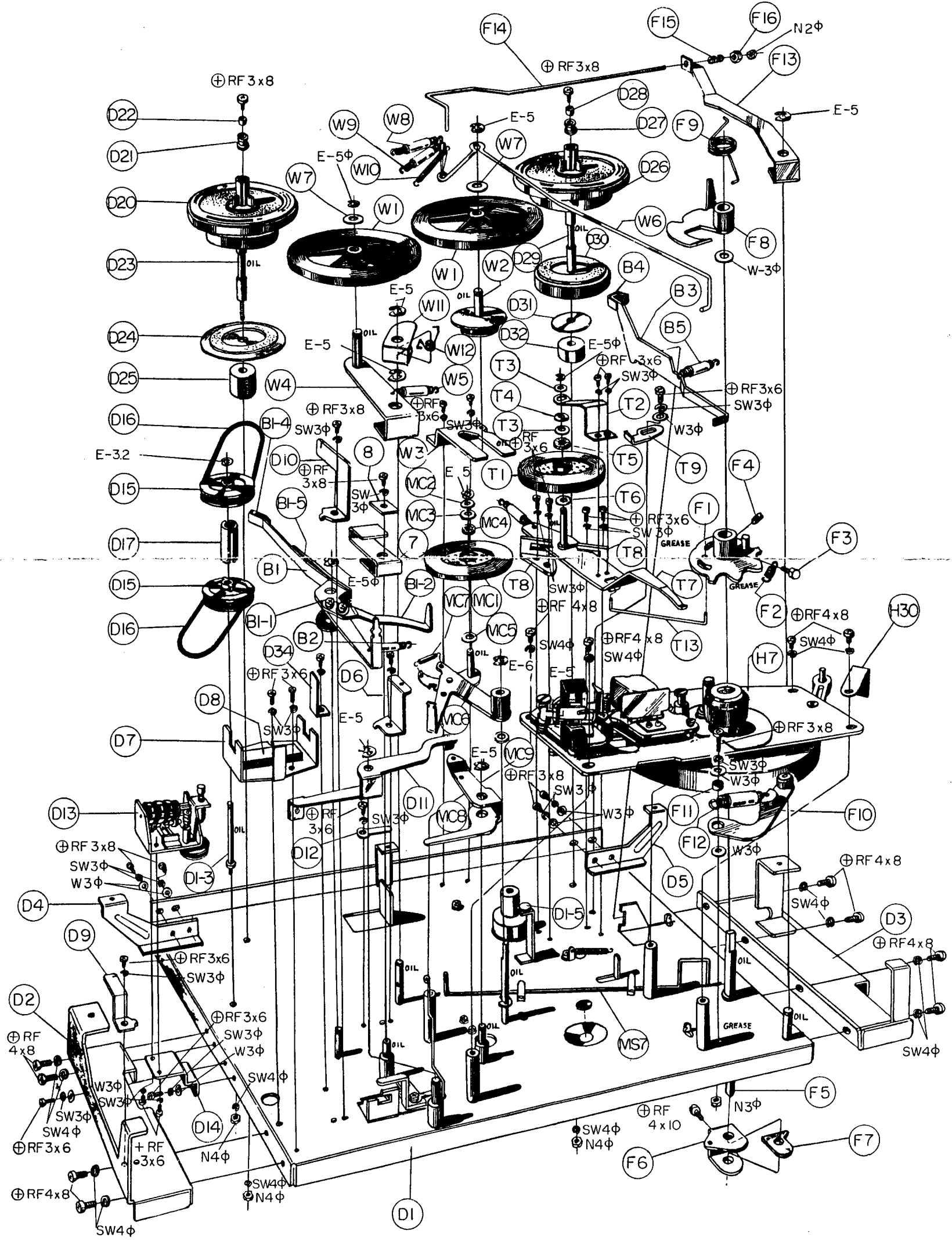

20

Cabinet Assembly

(Fig. 12)

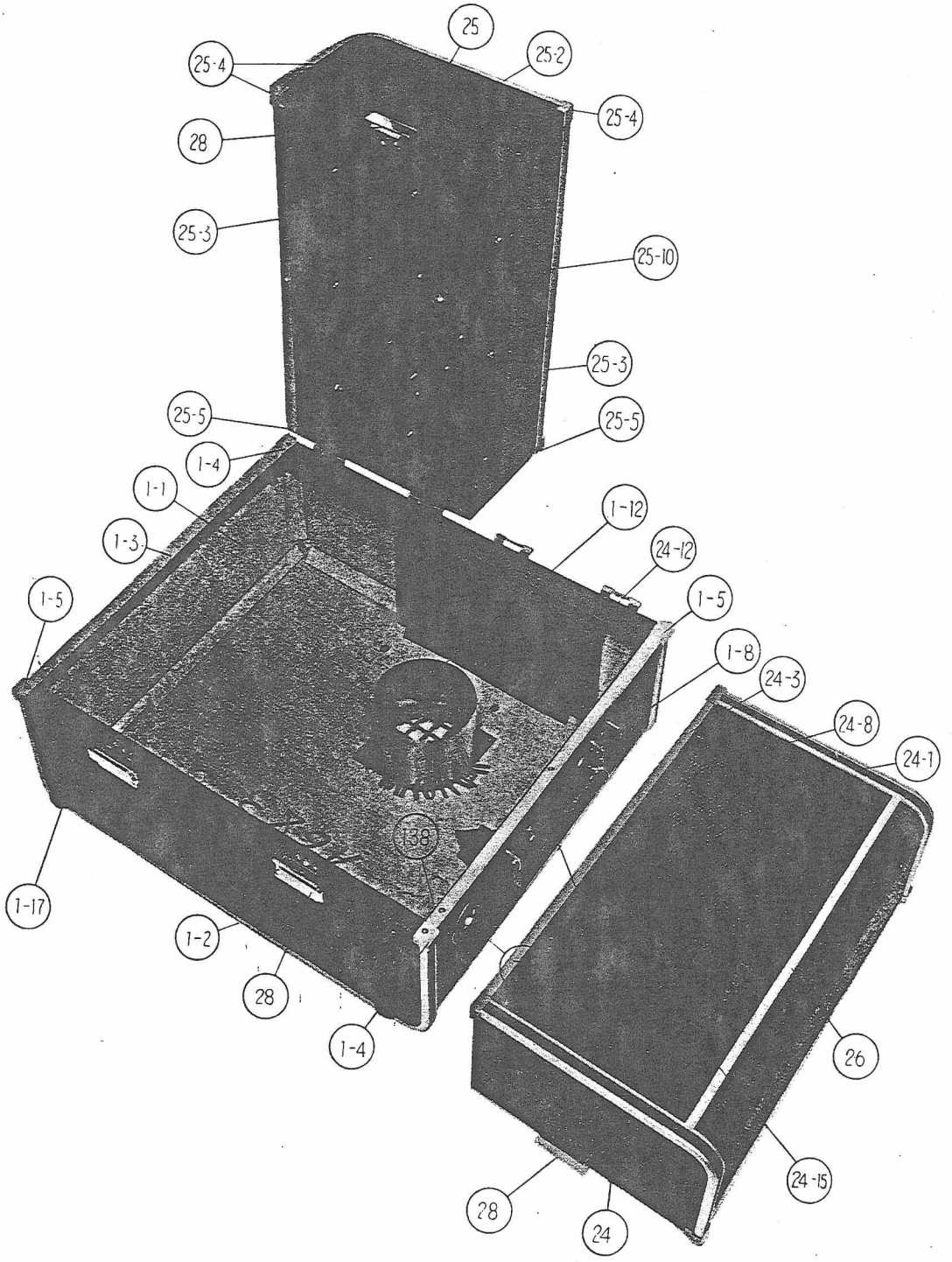

SONY CORPORATION

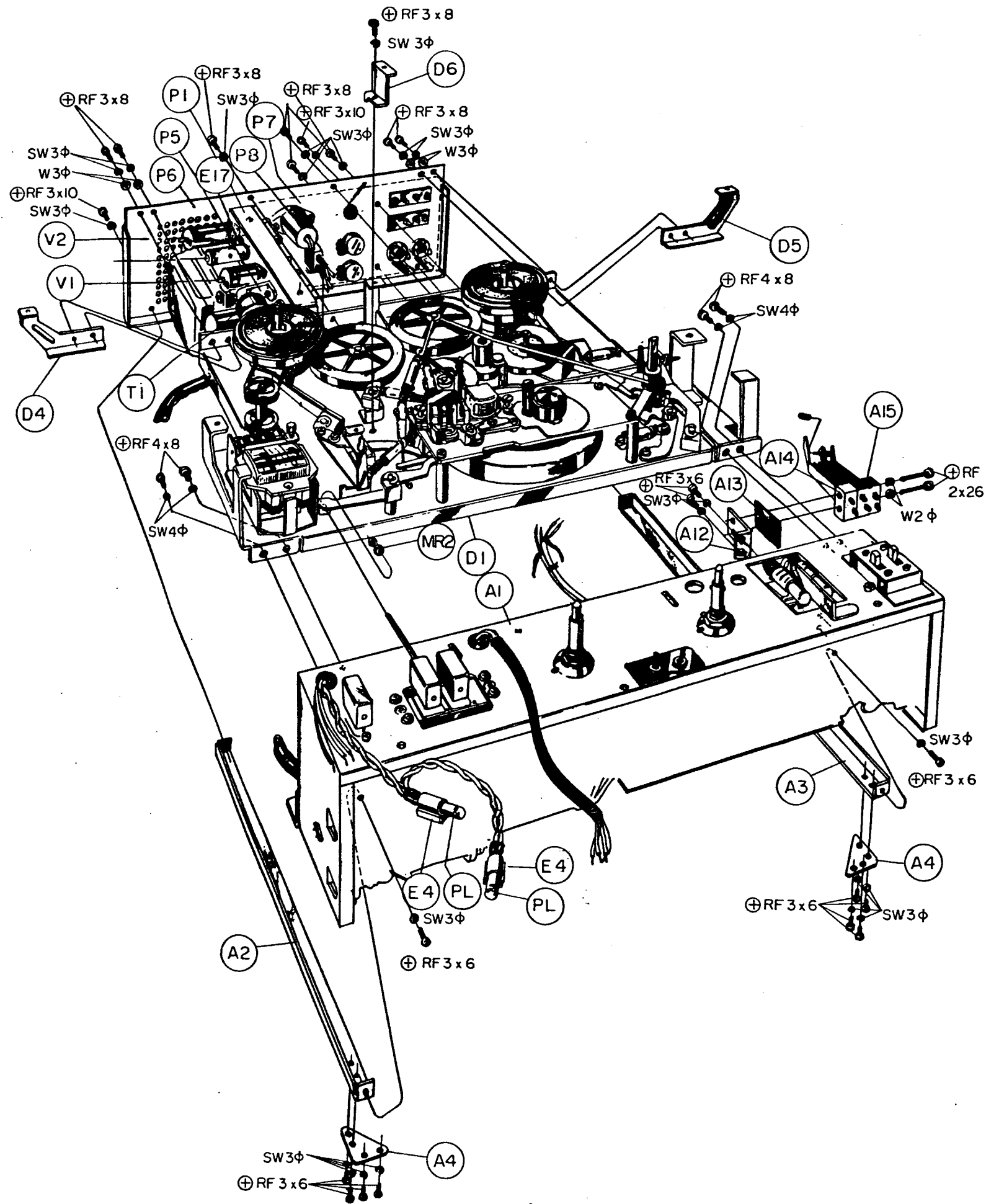



SERVICE MANUAL

SONY *Model* **500 & 500A**

SONY STERECORDER MODEL 500-500-A

Stereophonic Magnetic Tape Recorder

S E R V I C E M A N U A L

Table of Contents

SECTION 1	SPECIFICATIONS
SECTION 2	ELECTRONIC ALIGNMENT PROCEDURE
2.1.	Test Equipment Requirements
2.2.	General Precautions
2.3.	Playback Alignment
2.3.1.	Head Demagnetization
2.3.2.	Head Alignment
2.3.3.	Output Measurements
2.3.4.	Frequency Response (Playback)
2.3.5.	Meter Calibration (Playback)
2.3.6.	Hum Adjustments
2.3.7.	Bass Boost Adjustment
2.4.	Record Alignment
2.4.1.	Bias Adjustments
2.4.2.	Meter Calibration (Record)
2.4.3.	Frequency Response (Overall)
2.4.4.	Overall Noise Measurements
2.4.5.	Distortion Measurements
2.4.6.	Flutter and Wow Measurements
2.5.	Electronic Data
2.5.1.	Voltage Chart
2.5.2.	Electronic Parts List
2.5.3.	Circuit Diagram

Table of Contents (continued)

SECTION 3 MECHANICAL DISASSEMBLY PROCEDURE

- 3.1. Removal of Top Cover Panel
- 3.2. Removal of Loudspeaker
- 3.3. Removal of Capstan Sleeve and Pinch Roller
- 3.4. Removal of Head Assembly
- 3.5. Removal of Feed and Take-Up Reel Spindles
- 3.6. . . . Removal of Feed, Take-Up and Rewind Drive Pucks
- 3.7. Removal of Chassis from Case
- 3.8. Removal of Control Panel
- 3.9. Removal of Bottom Cover
- 3.10. Removal of Automatic Shut-Off Assembly
- 3.11. Removal of V. U. Meters
- 3.12. Removal of Record Pilot Lights
- 3.13. Removal of Tape Counter
- 3.14. Removal of Hysteresis Motor
- 3.15. Removal of Flywheel
- 3.16. Removal of Instant Stop Lever Assembly
- 3.17. Removal of Take-Up Brake Arm
- 3.18. Disassembly of Forward/Stop/Rewind Cam
Assembly

SECTION 4 MECHANICAL ADJUSTMENT PROCEDURE

- 4.1. Linkage from Record Button to Record/Play Switch
- 4.2. Linkage from Forward/Stop/Rewind to Automatic
AC Shut-Off Assembly
- 4.3. Motor Drive Pulley

SECTION 5 EXPLODED DIAGRAMS AND PARTS LIST

SECTION 1 - SPECIFICATIONS

The Sony Superscope STERECORDER Model 500 is a two-speed, two-channel, 1/4" magnetic tape recorder, capable of recording or reproducing four-track tapes.

The Model 500 contains two channels of pre-amplification and power amplification, one push pull bias oscillator, and a common power supply.

A 600 ohm winding on each output transformer provides a 600 ohm line out for each channel. This winding also supplies the energy for the V. U. meters. Heads are 1/4-track inline (stacked), and drive is by hysteresis synchronous motor.

TAPE SPEED

7-1/2" per second
3-3/4" per second

FREQUENCY RESPONSE (Overall)

Each channel measured at speaker output jacks or on line output jacks.

SPEED

7-1/2

RESPONSE

± 2db 50 to 14,000 cycles

SIGNAL TO NOISE RATIO

<u>Speed</u>	<u>Max. Record Level to Unweighted Noise</u>	<u>Peak Record Level to Unweighted Noise</u>
7-1/2	55db	45db
3-3/4	50db	40db

The peak record level is defined as that level at which the overall (input to output on "line jack") total RMS harmonic distortion does not exceed 1% when measured on a 400 cycle tone.

Noise is measured by playing an erased portion of the tape, on which a signal of peak recording level was present prior to erasure. This will produce the overall figure of noise, including the bias and erase noise, as well as the record and playback amplifier noise.

FLUTTER AND WOWSpeed

7-1/2
3-3/4

Flutter and Wow

Less than 0.17% RMS
Less than 0.25% RMS

The flutter and wow measurements include all components between 0 and 250 c/s.

SECTION 1 - SPECIFICATIONS

PLAYING TIME WITH 7-1/2" REEL (1200 feet of tape)

<u>Speed</u>	<u>Playing Time</u>	<u>Timing Accuracy</u>
7-1/2	32 minutes	0.3%
3-3/4	64 minutes	0.3%

OPERATION OF CONTROLS

DRIVE MECHANISM CONTROLS

All controls for complete operation of tape drive mechanism and speed selection are located in the upper control panel.

FORWARD/STOP/REWIND SELECTOR

This three-position selector is controlled by the large grey knob located on the right side of the upper control panel. FORWARD/STOP/REWIND functions are indicated in raised letters directly below the knob.

TO OPERATE

For FORWARD function turn the knob CLOCKWISE.

For REWIND function turn the knob COUNTER CLOCKWISE.

NOTE: Selection of FORWARD or REWIND must be made from CENTER or STOP position of the knob.

Do not change from FORWARD to REWIND (or vice versa) until tape comes to a complete stop.

FAST FORWARD LEVER

Fast forward selection is controlled by the chrome plated spring loaded lever located at the immediate left of the FORWARD/STOP/REWIND Selector Knob. It is indicated in letters "FAST FORWARD" with a small arrow pointing upward. The FAST FORWARD LEVER operates in both 3-3/4 and 7-1/2 ips.

TO OPERATE

After STERECORDER 500 is placed in normal forward motion at either speed, push FAST FORWARD LEVER upwards with a smooth quick movement until lever clicks into position then release lever. To stop FAST FORWARD motion, turn the FORWARD/STOP/REWIND Selector Knob to STOP position.

INSTANT STOP LEVER

This control is the plastic capped lever located on the left of the upper control panel. It is indicated in raised letters "INSTANT STOP" with a small raised arrow pointing to the left.

SECTION 1 - SPECIFICATIONS

When applied, this lever instantly and safely stops normal forward motion of the tape for editing and cueing. Both reels can still be rotated by hand in either direction while lever is applied.

TO OPERATE

Push lever to the left and hold until ready to release. Upon releasing the lever, the tape will immediately pick up full forward speed.

NOTE: *Do not apply INSTANT STOP while STERECORDER 500 is in FAST FORWARD or REWIND operation.*

AUTOMATIC SHUT-OFF SWITCH

This switch is controlled by the heavy wire sensing mechanism located to the left of the erase head underneath the head cover. After tape is threaded and the mechanism is placed in FORWARD motion, the shut-off lever automatically raises and rests against the tape. When the tape runs off the feed reel, the lever will activate a micro switch and shut off the recorder.

TAPE SPEED SELECTOR

Speed selection is controlled by the white knob located in the center of the upper control panel directly behind the head cover. This knob selects the desired speeds of either 3-3/4 ips or 7-1/2 ips, and automatically sets the proper recording and playback characteristics for each speed.

TO OPERATE

Your STERECORDER 500 is shipped with the TAPE SPEED SELECTOR in 3-3/4 ips position. To change from 3-3/4 ips to 7-1/2 ips, press down SPEED SELECTOR KNOB and turn clockwise to 7-1/2 ips position.

NOTE: *(Do not turn SPEED SELECTOR KNOB CLOCKWISE from 3-3/4 ips to 7-1/2 ips without first pressing knob down.) To change from 7-1/2 ips to 3-3/4 ips, simply turn SPEED SELECTOR KNOB counter-clockwise from 7-1/2 ips position to 3-3/4 ips position and allow knob to raise upwards.*

NOTE: *DO NOT CHANGE SPEED WHILE TAPE IS IN MOTION.*

TAPE COUNTER

A 3-digit numerical indicator is located at the left of the upper control panel. It is activated through a worm gear mechanism by a belt connected to the feed reel.

SECTION 1 - SPECIFICATIONS

TO OPERATE

Push white reset button, three zeros will appear in the window.

ELECTRONIC CONTROLS

All controls for complete operation of recording amplifiers, playback pre-amplifiers and monitor amplifiers, are located on the lower front control panel of the STERECORDER.

ON/OFF SWITCH

Located at the extreme left of the lower panel and operated by the white push button marked "AC-ON/OFF".

TO OPERATE

Push button down to turn recorder ON or OFF.

RECORD SELECTORS

Activated by the two coral colored push buttons located at the left side of the lower control panel and designated in raised letters "RECORD" directly above the buttons, and "CH-1" -- "CH-2" directly below.

TO OPERATE

Press the desired button (CH-1 for Channel 1, CH-2 for Channel 2, or both for stereophonic recording). Recording levels may then be adjusted before the mechanism is set in motion.

To start recording, keep the desired record button depressed; otherwise, it will automatically return to Playback mode when the Model 500 is placed in FORWARD position. These buttons are furnished with automatic mechanical safety interlocks to prevent accidental erasure of pre-recorded tapes.

LEVEL CONTROLS

Each channel is equipped with two level controls to increase or decrease recording and playback levels. These controls are operated by the round knobs mounted coaxially on the left and right center of the lower control panel. They are designated respectively "CH. 1 and CH. 2".

SECTION 1 - SPECIFICATIONS

The lower knob on each channel is operative only in recording mode and controls the recording level of the auxiliary inputs. The upper knob on each channel serves a dual purpose:

- (1) In "Record Mode": They control the recording level of the microphone inputs.
- (2) In "Play Mode": They control the playback level. Reference calibrations for level controls are numbered from "0-10".

NOTE: The feature of separate level controls for microphone and auxiliary inputs provide the facilities to mix "live" microphone recording simultaneously with recordings made from stereo tuners, stereo discs, or any other auxiliary source.

RECORD LAMPS

Located at the right of the lower control panel and designated in raised letters "REC. LAMP" directly above the lamps, and "CH-1" -- "CH-2" directly below. When the desired RECORD BUTTON is pressed, the respective red LAMP will light up, indicating which Channel of the 500 is in recording mode; (RECORD BUTTON CH-1 and CH-2 for RECORD LAMP CH-1 and CH-2 respectively, or both BUTTONS for both LAMPS.)

CONTOUR SWITCH (Bass Boost)

This 2-position switch is controlled by the left slide button located on the right of the lower control panel. It is designated in raised letters "CONTOUR-BASS-FLAT". With the slide button in "BASS" position, there is a preset boost in the lowest frequencies of approximately 8db to compensate for the lack of bass response at low level listening or of small monitor speakers.

With the slide button in "FLAT" position, the frequency response of the STERECORDER 500 is flat within the quoted specifications. It is suggested that when the STERECORDER 500 is used in connection with external pre-amplifiers and power amplifiers, the CONTOUR SWITCH be placed in "FLAT" position.

SPEAKER SWITCH

This 2-position slide switch is controlled by the slide button designated in raised letters "SPKR-ON-OFF" and is located on the extreme right of the lower control panel.

This switch controls the output of the external speaker jacks. It is used to turn on or off, the speakers which are supplied or other speakers which are connected to the external speaker output jacks.

NOTE: When connected to external pre-amplifiers and amplifiers through Line Output, the SPEAKER SWITCH (14) may be in "OFF" or "ON" position as desired.

SECTION 1 - SPECIFICATIONS

V. U. METERS

Two V. U. meters are provided with the STERECORDER 500 for extremely accurate recording and playback level indication.

These meters are calibrated to NAB standards to allow the maximum recording level without distortion. For best recording results, the level controls should be adjusted so that the deflection of the V. U. indicator needle does not exceed 100%.

It is normal for transient peaks to occasionally deflect the needle into the red zone; however, the level should be lowered slightly if these peaks cause the needle to hit against the stop pin beyond the red zone.

INPUT AND OUTPUT CONNECTIONS

All input and output facilities, with the exception of microphone inputs, are located on the rear of STERECORDER 500 chassis.

MICROPHONE INPUTS

There are two microphone inputs located in the center of the lower front panel and indicated "MIC" in raised letters. Channel 1 and Channel 2 are indicated respectively on the left and right of each input. These input jacks are of the "Mini-jack" variety and accept the standard 5/8" tip "Mini" type plug. The microphone input impedance is engineered for the Sony F-86, F-87 and F-96 Microphones or any high quality dynamic microphone of the high impedance variety.

AUXILIARY INPUTS

The two auxiliary inputs are located on the upper left rear of the chassis, and designated "AUX. INPUT".

These inputs are high impedance and are used for recording from any components that deliver a signal of not less than 0.15 volt, such as: AM/FM tuners, TV, Tape Recorders, or pre-amplifier "recorder" outputs. Direct connection of tape heads or magnetic phono cartridge without the use of external pre-amplifiers is not recommended.

Recording from Ceramic phono cartridges can be connected directly to the Microphone inputs.

LINE OUTPUTS

The 2 Line Outputs are located on the center left rear of the chassis, and are designated "LINE OUT".

SECTION 1 - SPECIFICATIONS

These outputs are high level 600 ohm impedance and are used to connect the STERECORDER 500 to external pre-amplifiers and amplifiers.

PROPER CONNECTION FOR EXTERNAL AMPLIFICATION

It is important when using external pre-amplifiers and power amplifiers from LINE OUTPUTS that the playback level controls of the STERECORDER 500 be properly adjusted. It is recommended that these level controls be adjusted at a point below the Number 7 on the dial calibration. Control of volume can then be accomplished with the volume controls of the external pre-amplifiers. Keeping the output level of the STERECORDER 500 relatively low avoids the possibility of overloading the input of the external pre-amplifier, thereby avoiding distortion and hum.

SPEAKER OUTPUTS

The two Speaker Outputs are located on the lower left rear of the chassis and are designated "SPEAKER".

These outputs are for connection to external speakers or low impedance earphones from the built-in amplifiers. They are 8 ohm impedance and deliver approximately 6 watts of peak power per channel.

AC RECEPTACLES

There are three AC receptacles located on the rear of the chassis. The upper round receptacle is for connection of the main power cord to the STERECORDER 500.

The two other rectangular receptacles below the main power receptacle are for convenient power connection of other components. The left receptacle is a direct 117 volt connector and is "hot" even though the power switch to the STERECORDER 500 is off.

The right receptacle is operative only when the power switch and automatic shut-off switch of STERECORDER 500 are "ON".

BINAURAL MONITOR

Located near the front, on the right side of the STERECORDER 500, is a binaural monitor jack. It has a 100 ohm impedance and will accept Sony Binaural Headphones DR-1A, DR-1C and SHS-2, or any comparable headphone, high or low impedance, equipped with a binaural phone plug. Control of the output level is accomplished by the playback level control.

SECTION 1 - SPECIFICATIONS

POWER REQUIREMENTS

The Model 500 STERECORDER operates from 117 volts AC. The standard model operates on 60 c/s supply.

The power consumption is approximately 110 watts.

SECTION 2 - ALIGNMENT PROCEDURE

After a major repair or head replacement has been made, it is recommended that a complete checkout of the STERECORDER be performed. In this section, the general procedure for checking and aligning the STERECORDER Model 500 is outlined.

The alignment has to be performed only at 7-1/2 ips. The performance at 3-3/4 ips will meet the specifications if the machine operates normally at 7-1/2 ips.

2.1 Alignment and test equipment requirements for proper alignment and testing:

- a. Audio Oscillator - Hewlett-Packard Model 200CD or equivalent.
- b. Vacuum Tube Voltmeter - Hewlett-Packard Model 400D or equivalent.
- c. Head Demagnetizer.
- d. Alignment Tape - Ampex Catalog #31321-04 or equivalent.*

2.2 General Precautions:

- a. It is always advisable to demagnetize the REC/PLAY head BEFORE putting an alignment tape on the STERECORDER. Magnetization of the head will cause partial erasure of the high frequencies on the tape and therefore make it useless as a standard. Demagnetization procedure is given under Paragraph 2.3.1.
- b. The output of the STERECORDER must always be properly terminated when testing or aligning. The speaker output impedance of the STERECORDER is 8 ohm.
- c. Never leave the right-hand knob in FORWARD position after the AC power is off.
- d. Never change speeds while the mechanism is in FORWARD motion.
- e. Demagnetize all metal tools which will be used to repair or adjust instrument.

2.3 Playback Alignment:

2.3.1. Head Demagnetization

Before threading the alignment tape, the REC/PLAY head must be demagnetized. During use, the head may occasionally become permanently magnetized by allowing the heads to come into contact with a magnetized object. Magnetized heads will cause considerable increase in the noise level and may ruin good tapes by partially erasing the high frequencies. The following precautions are recommended to avoid head magnetization:

* A suitable playback alignment tape is available from Superscope, Inc., at a cost of \$7.50.

SECTION 2 - ALIGNMENT PROCEDURE

- a. Do not remove any tubes from the amplifier while the STERECORDER is operating in REC. mode.
- b. Do not connect or disconnect input leads while recording.
- c. Do not test continuity of the heads with an ohmmeter.
- d. Do not saturate the RECORD amplifier with abnormally high input signals.
- e. Do not change from Stereo to Monophonic or vice versa while in recording mode.

Whenever necessary, the following demagnetization procedure can be performed:

With the STERECORDER switched off, the REWIND/STOP/FORWARD knob in STOP position, plug a demagnetizer into an AC main outlet. Bring the tips of the demagnetizer into close proximity to - but not in contact with - the head core stacks. Run the tips of the demagnetizer up and down the entire length of the core stack three or four times. The tips of the demagnetizer should straddle the gaps. Remove the demagnetizer VERY SLOWLY, allowing the influence of its AC field to die off gradually. In case demagnetization is not effected, repeat process.

2.3.2. Alignment of the Head.

a. Elevation Alignment - There are facilities for the adjustment of the vertical positioning of the head in relation to the tape. The exact vertical positioning of the head is adjusted at the factory and should never need readjustment. However, when replacing the head, the height of the new head must be checked. Thread a tape on the instrument and observe that during tape motion, the tape is approximately .0015" (1.5 mils) above the top edge of the upper head core of the record/Playback head and approximately .0015" (1.5 mils) below the top edge of the upper head core of the erase head. If the tape fails to track within these limits, it may result in poor erasure, cross talk, or unbalance in output. Correction for tracking error is accomplished by the adjustment of the two tape guides located to the right and left of the head assembly. If slots on the top of the tape guides are covered with red paint, remove paint and with a screw driver, adjust for proper tracking.

b. Azimuth Alignment - The azimuth alignment screw is located on the right side of the REC/PLAY head. It also serves the purpose of securing the head. With the STERECORDER in stereo mode, thread the alignment tape, turn playback level controls clockwise and during playback of the 10k cps recorded tone on the tape, adjust the azimuth alignment screw to obtain the maximum reading on the V. U. meters. Keep V. U. meter reading below 100% by turning level controls counter-clockwise if necessary.

SECTION 2 - ALIGNMENT PROCEDURE2.3.3. *Output Measurement*

Connect an 8 ohm 3 watt load resistor in parallel with the VTVM terminals; connect the VTVM to Channel 1. Adjust the playback level controls to their maximum settings. Run the alignment tape. The tone following the 10k cps for azimuth alignment is a 250 cps tone, recorded at maximum operating level. Note the reading on the VTVM; it should be more than 4.9 volts. Switch the VTVM to Channel 2. At least 4.9 volts must again be obtained.

2.3.4. *Frequency Response (Playback)*

NOTE: Before making a frequency response test, be sure the alignment of the head is correct, and the contour switch is in the FLAT position. Set VTVM on +10db range and, using the alignment tape (250 cps recorded at operating level), adjust each of the individual volume controls, until a reading of 0db on the VTVM scale is obtained on both channels. Mark the volume control settings for this reading and do not touch these controls until all the adjustments are made.

The next tone in the alignment tape is a reference tone, recorded at -10db. Set the VTVM to the 0db range. The reading will be again 0db on the VTVM scale.

Following this tone, there is a sequence of tones for frequency response check: Using the first of these tones (10k cps), adjust the treble playback equalization to obtain a reading of +2db on the VTVM. All other tones on the tape should then give a reading of ± 2 db from the reference point of 0db. If necessary, readjust the treble equalization to +2db while playing back the second tone (7.5k cps). Treble equalization controls R107 and R207 are located in the amplifier chassis, below the microphone input jacks.

2.3.5. *Meter Calibration-Playback*

With the VTVM set to the +10db range and connected as in preceding paragraphs, rewind the alignment tape to the second signal (250 cps recorded at maximum level). Replay this section of the tape and adjust R135 and R235 to obtain a reading of 80% on the V. U. meters. R135 is located in the lower left-hand corner in the amplifier chassis, while R235 is in the lower right-hand corner.

2.3.6. *Hum Adjustment*

Defeat of the automatic stop lever by holding in the ON position with a piece of masking tape. Remove the alignment tape from the machine and, with the volume controls as adjusted previously, turn the right-hand control knob to FORWARD. Adjust the filament balancing potentiometers

SECTION 2 - ALIGNMENT PROCEDURE

(1 for each channel) for a minimum reading on the VTVM. If this reading is not at least 45db below the reading obtained when setting the + 10db reference level, then the hum bucking coils must be adjusted. Remove the large metal cover from the bottom of the instrument and you will observe two small coils about the size of a one-cent coin, located near the input tubes (V1 and V4). The left coil is for Ch. 1 and the right coil is for Ch. 2. Orient these coils for minimum reading on VTVM.

When the above steps have been taken, the hum level should be 45db or more below the reference level. If this is not achieved, replace input tube (12AD7) and/or the next (6AU6) tube.

2.3.7. Bass Boost Adjustment

Locate the section of the alignment tape which is recorded at 100 cps. While playing this section, switch the contour switch to the bass position. The output should increase approximately 5db in the bass position.

2.4

Record Alignment:

2.4.1. Bias Adjustment

Remove top panel and attach auxiliary head between capstan and tape motion control knob. Connect the top track of the auxiliary head to the VTVM. Thread a blank tape on the instrument and be sure that the top edge of the tape tracks with the top edge of the upper pole piece of the auxiliary head. Feed a 1000 cps signal of approximately .1 volt into the auxiliary input of Ch. 1. Place the STERECORDER in record mode by depressing the record button and turning the tape motion control knob to the FORWARD position. The auxiliary head will monitor the recorded signal a fraction of a second after it is recorded. Adjust the bias current by turning the screw in the trimmer capacitor. The bias trimmers are located in the amplifier chassis, low and near the middle. The left trimmer is for Ch. 1 and the right trimmer is for Ch. 2. During the adjustments, starting with the adjustment screw loose, the VTVM reading will go up, reaching a maximum and then falling again. The correct adjustment is the one that gives a reading between the maximum and 0.5db below and beyond this value. The optimum bias adjustment will vary slightly with different tapes. Note that there will be a small time delay in the VTVM reactions to the adjustments. This is due to the distance between the recording head and the auxiliary head.

SECTION 2 - ALIGNMENT PROCEDURE

After completing the bias adjustment for Channel 1, change the input signal to Channel 2 Auxiliary Input and repeat the procedure, this time adjusting the Channel 2 trimmer. Be sure to connect the VTVM to the bottom track of the auxiliary head.

It should be noted that under-biasing favors the high frequencies, but increases the distortion. Over-biasing gives a lower high frequency response, but decreases the distortion. The procedure outlined corresponds to the best compromise and is of standard practice in tape recording technique.

2.4.2. Meter Calibration - Record

The adjustment of the meters consists of setting the amount of signal derived from the RECORD amplifier to the V.U. meters, so that the meter reads 100% when the level of a 250 cps tone being recorded is the same as the level of the second tone of the Ampex alignment tape, which corresponds to approximately 12db below the tape saturation. The following steps must be followed to properly adjust the meters:

Set the playback volume controls to the reference level as established in the procedure for testing playback frequency response. Feed a 250 cps signal of approximately .3 volt into the Ch. 1 auxiliary input jack. Place the STERECORDER in the record mode and adjust the Ch. 1 auxiliary record level control until the Ch. 1 V.U. meter reads 100% and record this signal. Connect the VTVM to Ch. 1 speaker output and play back this recording. A reading of +10db should be indicated. If not, the V.U. meter must be calibrated by the following procedure:

Either increase or decrease the output level of the signal generator to compensate for any deviation from the desired reading of +10db in the above. Record the signal again at this new level and adjust R136 until the V.U. meter reads 100%.

Do not adjust auxiliary control knob or change playback reference setting. When this recording is played back, a reading of +10db will be indicated on the VTVM if the procedure was followed correctly. Repeat the procedure for Ch. 2 and adjust R236. R136 is located directly over R135 and R236 is directly over R235.

NOTE: The contour switch must be in the FLAT position.

2.4.3. Overall Frequency Response

Thread a new tape on the machine. Record several frequencies from 12k cps to 50 cps, maintaining the input voltage constant at 7-1/2 ips.

SECTION 2 - ALIGNMENT PROCEDURE

Play back these frequencies. The response, provided the bias adjustment is correct, will fall within the range of $\pm 2\text{db}$ from a reference level taken at 250 cps. It is useful to remember that excessive bias current will cause the high frequency end to drop off.

Note 1 - Due to the nature of the pre-emphasis in the record circuit, tape saturation will occur at the high frequencies unless the response check is made at least 10db below normal operating level. The input signal, therefore, must be 10db lower than the one that gives a reading of 100% on the meters when the machine is in RECORD mode.

Note 2 - The contour switch must be in the FLAT position.

2.4.4. Overall Noise Measurements

The overall noise is measured by finding the ratio between the signal level that gives a total harmonic distortion of 3% at 400 cps and the noise obtained when a tape recorded at 400 cps peak level is erased on the recorder (controls set as per 2.3.4. and no input signal to the recorder) and played back on the same recorder.

Note - The 3% THD level corresponds to approximately 6db above the peak recording level.

Note - When performing noise measurements, be certain that the heads are clean and demagnetized.

2.4.5. Distortion Measurements

Overall harmonic distortion can be measured by using any standard distortion measurement apparatus across the output. The readings from a wave analyser or selective frequency distortion meter will be more accurate than those from a null type instrument at lower distortion levels. Distortion readings are somewhat dependent on tape. A reading of less than 1.5% should be obtained on overall test with the maximum operating level recorded on the tape and the volume controls set to approximately 1.5-watt power output.

2.4.6. Flutter and Wow Measurements

Flutter and wow are produced by periodic irregularities in tape speed and appear as cyclic frequency deviations in recording or reproduction. They can be measured by means of any standard wow and flutter bridge. Note that variations in amplitude, as noticed sometimes on level measurements, do not constitute wow or flutter and are entirely due to tape coating variations. Readings on the wow and flutter bridge will be well under 0.17% for 7-1/2 ips and 0.25% for 3-3/4 ips speeds.

2.5.1. MODEL 500 VOLTAGE CHART

<u>Tube</u>	<u>1</u>	<u>2</u>	<u>3</u>	<u>4</u>	<u>5</u>	<u>Pin</u> <u>6</u>	<u>7</u>	<u>8</u>	<u>9</u>
V101 12AD7	65	-.5	0	Fil	Fil	140	0	.8	Fil
V102 6AU6	0	1.0	Fil	Fil	40	70	1.0		
V103 6AQ5	0	12	Fil	Fil	245	250	0		
V201 12AD7	65	-.5	0	Fil	Fil	140	0	.8	Fil
V202 6AU6	0	1.0	Fil	Fil	40	70	1.0		
V203 6AQ5	0	12	Fil	Fil	245	250	0		
V1 12BH7	275	-38	0	Fil	Fil	275	-38	0	Fil
V2 6CA4	300AC		360	Fil	Fil			300AC	

All voltages DC except as noted.

Voltages measured with VTVM, Chassis is B-.

Voltages for V1 measured in Record mode.

2.5.2. Electrical Parts List inside.

SYMBOL	N A M E	SPECIFICATION	SYMBOL	N A M E	SPECIFICATION	SYMBOL	N A M E	SPECIFICATION	SYMBOL	N A M E	SPECIFICATION
V ₁	VACUUM TUBE	12BH7	R ₁	CARBON RESISTOR	3.5KΩ RD2L ±10%	R ₁₃₇	CARBON RESISTOR	1.5KΩ RD½L ±5%	C ₁₆	ELECTROLYTIC CAPACITOR	3μF 350 WV
V ₂	"	6CA4	R ₂	"	10KΩ RD½L "	R ₁₃₈	"	18KΩ " ±10%	C ₁₇	MYLAR CAPACITOR	0.01μF 100 WV ±10%
V ₂₀₁	"	12AX7 or 12AD7	R ₃	"	" " "	R ₁₃₉	"	600Ω " "	C ₁₈	MICA CAPACITOR	400PF 400 WV "
V ₂₀₂	"	6AU6	R ₄	"	100KΩ " "	R ₁₄₀	"	8Ω RD2L "	C ₁₉	MYLAR CAPACITOR	0.02μF 100 WV "
V ₂₀₃	"	6AQ5	R ₅	"	" " "	R ₁₄₁	WIRE WOUND RESISTOR	2Ω ½ W "	C ₂₀	OIL PAPER CAPACITOR	0.05μF 400 WV ±20%
T ₁	OSC. TRANSFORMER		R ₆	WIRE WOUND ENAMELED RESISTOR	1KΩ 16W "	R ₁₄₂	CARBON RESISTOR	220Ω RD¼L ±5%	C ₂₁	MICA CAPACITOR	150PF 400 WV ±5%
T ₂	POWER TRANSFORMER		R ₇	POTENTIO METER	300Ω				C ₂₂	ELECTROLYTIC CAPACITOR	25μF 15 WV
T ₂₀₁	OUTPUT TRANSFORMER		R ₈	"	"				C ₂₃	MYLAR CAPACITOR	0.001μF 100 WV ±10%
R.P.H.	RECORD PLAYBACK HEAD		R ₉	CARBON RESISTOR	200Ω RD½L ±10%				C ₂₄	ELECTROLYTIC CAPACITOR	10μF 350 WV
E.H.	ERASE HEAD										
M	MOTOR										
J ₁	BINAURAL MONITOR JACK		R ₁₀₁	POTENTIO METER	500MA±500KA)						
J ₂₀₁	LINE INPUT JACK	RCA TYPE PIN JACK	R ₁₀₂	CARBON RESISTOR	250KΩ RD½L ±10%	C ₁	OIL PAPER CAPACITOR	0.1μF 400 WV ±20%			
J ₂₀₂	MIC INPUT JACK	MINI JACK	R ₁₀₃	"	5MΩ " "	C ₂	SEMI FIXED CAPACITOR	30-200PF			
J ₂₀₃	LINE OUTPUT JACK	RCA TYPE PIN JACK	R ₁₀₄	"	250KΩ " "	C ₃	"	30-200PF "			
J ₂₀₄	SPEAKER OUTPUT JACK	PHONO JACK	R ₁₀₅	"	8.5KΩ " ±5%	C ₄	MICA CAPACITOR	300PF 400 WV ±10%			
S ₁	REC/P-B SWITCH	SLID SWITCH	R ₁₀₆	"	50KΩ " ±10%	C ₅	MP CAPACITOR	0.5μF 25 WV ±20%			
S ₂	"	"	R ₁₀₇	SEMI FIXED RESISTOR	10KΩ (B) 17L	C ₆	MICA CAPACITOR	0.002μF 400 WV ±5%			
S ₃	EQUALIZER SWITCH	PUSH SWITCH	R ₁₀₈	CARBON RESISTOR	75KΩ RD½L ±10%	C ₇	"	" " "			
S ₄	BASS BOOST SWITCH	SLID SWITCH	R ₁₀₉	"	82KΩ RD¼L ±5%	C ₈	"	" " "			
S ₅	SPEAKER SWITCH	"	R ₁₁₀	"	500KΩ RD½L ±10%	C ₉	ELECTROLYTIC CAPACITOR	40μF 400 WV			
S ₆	MUTING SWITCH	LEAF SWITCH	R ₁₁₁	"	1.5KΩ " "	C ₁₀	"	" 350 WV			
S ₇	BIAS OSCILLATOR SWITCH	"	R ₁₁₂	"	100KΩ " "	C ₁₁	ELECTROLYTIC CAPACITOR	20μF x 4 450 WV			
S ₈	"	LEAF SWITCH	R ₁₁₃	"	330KΩ RD¼L ±5%	C ₁₂	MP CAPACITOR	1.5μF + 0.5μF			
S ₉	POWER SWITCH	PUSH SWITCH	R ₁₁₄	POTENTIO METER	500MA±500KA)	C ₁₃	"	250V AC ±10%			
S ₁₀	AC SHUT-OFF SWITCH	MICRO SWITCH	R ₁₁₅	CARBON RESISTOR	30KΩ RD½L ±10%	C ₁₄	OIL PAPER CAPACITOR	0.25μF 600 WV ±20%			
CN ₁	CONNECTOR		R ₁₁₆	"	180KΩ RD¼L ±5%						
CN ₂	"		R ₁₁₇	"	180KΩ " "						
CN ₃	"		R ₁₁₈	"	250KΩ RD½L ±10%						
CN ₄	"		R ₁₁₉	"	100Ω " "						
CN _P	SHORT PLUG		R ₁₂₀	"	1.5KΩ " "						
VU ₂₀₁	VU METER		R ₁₂₁	"	200KΩ " "						
PL ₁	PILOT LAMP	6-8V REGULAR LAMP	R ₁₂₂	"	62KΩ " "	C ₂₀₁	MYLAR CAPACITOR	0.1μF 100 WV ±20%			
PL ₂₀₁	"	"	R ₁₂₃	"	500KΩ " "	C ₂₀₂	ELECTROLYTIC CAPACITOR	10μF 350 WV			
F	FUSE	2A	R ₁₂₄	"	30KΩ " "	C ₂₀₃	MYLAR CAPACITOR	0.05μF 200 WV ±20%			
L ₁	DUMMY COIL		R ₁₂₅	"	250KΩ " "	C ₂₀₄	"	0.015μF 100 WV ±5%			
L ₂₀₁	TRAP COIL		R ₁₂₆	"	50KΩ " "	C ₂₀₅	"	0.002μF 100 WV ±10%			
L ₂₀₂	HUM BACK COIL		R ₁₂₇	"	150KΩ RD¼L ±5%	C ₂₀₆	MICA CAPACITOR	300PF 400 WV ±5%			
SP ₂₀₁	SPEAKER	4 INCHES	R ₁₂₈	"	270KΩ " "	C ₂₀₇	"	750PF 400 WV "			
			R ₁₂₉	"	180KΩ " "	C ₂₀₈	ELECTROLYTIC CAPACITOR	50μF 6 WV			
			R ₁₃₀	"	500KΩ RD½L ±10%	C ₂₀₉	ELECTROLYTIC CAPACITOR	10μF 350 WV			
			R ₁₃₁	"	250Ω RD2L "	C ₂₁₀	MYLAR CAPACITOR	0.05μF 200 WV ±20%			
			R ₁₃₂	"	2KΩ RD¼L "	C ₂₁₁	ELECTROLYTIC CAPACITOR	50μF 6 WV			
			R ₁₃₃	"	100Ω RD¼L "	C ₂₁₂	"	3μF 350 WV			
			R ₁₃₄	"	3.3KΩ RD½L ±5%	C ₂₁₃	ELECTROLYTIC CAPACITOR	10μF 350 WV			
			R ₁₃₅	SEMI FIXED RESISTOR	10KΩ (B) 17L POT	C ₂₁₄	MYLAR CAPACITOR	0.04μF 100 WV ±10%			
			R ₁₃₆	"	" " " "	C ₂₁₅	MICA CAPACITOR	50PF 400 WV "			

NOTE THE FOLLOWING CHANGES FOR MODEL 500 A

R₆ 600Ω 16W
R₁₂₆ SEMI FIXED RESISTOR 50KΩ
R₁₂₇ CARBON RESISTOR 33KΩ RD¼L 5%
C₁₁₇ CAPACITOR .015μF
C₂₁₈ CAPACITOR 50pfd

SECTION 3 - MECHANICAL DISASSEMBLY PROCEDURE

MECHANICAL DESIGN

The STERECORDER is composed of three major mechanical assemblies:

1. *Tape transport mechanism.*
2. *Electronics chassis containing all controls, jacks and switching mechanisms.*
3. *Portable case for housing the above, together with monitor speakers, cables and accessories.*

3.1 **REMOVAL OF TOP COVER PANEL**

- A. *Remove 5 phillips head screws and chrome cup washers, being careful not to loosen plastic washers from decorative metal washers.*
- B. *Lift panel from recorder.*

3.2 **REMOVAL OF LOUDSPEAKER**

- A. *Remove 6 oval head wood screws and washers from rear of speaker enclosure.*
- B. *Remove rear panel.*
- C. *Remove acoustical lining placed over speaker.*
- D. *Unsolder speaker leads - note connections - speaker leads must be installed to the correct terminals.*
- E. *Remove 4 nuts, lockwashers and washers from speaker mounting flange. Remove speaker.*

NOTE: *Replace acoustical lining pads in their proper position.*

3.3 **REMOVAL OF CAPSTAN SLEEVE AND PINCH ROLLER**

- A. *Remove knurled screw on top of capstan (counter-clockwise).*
- B. *Insert thin V-shaped wedge between shaft and capstan sleeve and apply leverage to loosen sleeve from capstan shaft.*
- C. *Remove large diameter knurled screw from top of pinch roller and remove (when re-assembling capstan sleeve, be certain that the tapered shaft and inner surface of capstan sleeve are absolutely free of oil, dust and grit).*

SECTION 3 - MECHANICAL DISASSEMBLY PROCEDURE3.4 REMOVAL OF HEAD ASSEMBLY

- A. Remove 4 screws at corners of base plate. When re-assembling, make sure to replace small pressure springs on each screw.

3.5 REMOVAL OF FEED AND TAKE-UP REEL SPINDLES

- A. Unscrew (counter-clockwise) the phillips head screw and plastic "O" ring on each spindle.
- B. Remove drive belt from tape counter.
- C. Push take-up brake shoe to one side and remove take-up spindle.
- D. Push rewind puck to one side and remove feed spindle.

NOTE: Each respective shaft is bolted in place underneath the steel base plate.

3.6 REMOVAL OF TAKE-UP, REWIND AND DRIVE PUCKS

- A. Remove snap washers and composition washers.
- B. Push aside rewind push rods for accessibility and pucks can be slipped off. When re-assembling, make sure that brake block (Ref. 92) adjacent to rewind puck is in proper position.
- C. Use care to avoid bending the flat tension spring. Erratic operation of Fast Forward when the STERECORDER 500 is in a vertical position will result if this spring is deformed.

NOTE: The following procedures require removal of the chassis from the portable case.

3.7 REMOVAL OF CHASSIS FROM CASE

- A. Disconnect AC line from chassis.
- B. Remove speakers.
- C. Remove fuse and cap.
- D. Place recorder face down on padded surface.
- E. Remove 2 machine screws and washers under handle.
- F. Remove 4 screws and washers from back of case.
- G. The chassis can now be removed from case.

3.8 REMOVAL OF CONTROL PANEL

- A. Remove head cover.
- B. Remove speed change knob.
- C. Remove plastic cap from instant stop lever.
- D. Remove function control knob.
- E. Remove mike/play knobs - pull off.
- F. Remove auxiliary knobs - set screw.

SECTION 3 - MECHANICAL DISASSEMBLY PROCEDURE

- G. Remove phillips screw and washer under head cover and both tape guides.
- H. Remove electronics bottom cover; loosen 3 oval head phillips screws on rear of chassis; cover will then slip out.
- I. Remove 3 phillips head screws and washers - located just under lip of electronics chassis.
- J. Lift control panel from recorder.

3.9 REMOVAL OF BOTTOM COVER

- A. Remove from case.
- B. Loosen 3 oval head phillips screws on rear of chassis.
- C. Pull down on cover, then remove.

3.10 REMOVAL OF AUTOMATIC SHUT-OFF SWITCH ASSEMBLY

- A. Remove the head cover by pulling directly away from panel.
- B. Remove 2 phillips machine screws holding micro-switch to bracket.
- C. Unsolder leads.
- D. Adjust hum coils as per paragraph 2.3.6. after replacing micro-switch.

3.11 REMOVAL OF V. U. METERS

- A. Follow paragraphs 3.1, 3.7 and 3.8.
- B. Lift V. U. meters from mounting. Unsolder leads, if necessary.
- C. To replace V. U. meter lights:
 - (1.) Slide lights and sockets from supports.
 - (2.) Unscrew old lights, replace with new.
 - (3.) Slide onto supports.
- D. To zero meters:
 - (1.) Pull V. U. meters from mounting.
 - (2.) Zero set screws are located:
 - Channel 1 - upper left side
 - Channel 2 - lower right side

3.12 REMOVAL OF RECORD PILOT LIGHTS

- A. Remove front control panel and these pilot lights are readily accessible.

3.13 REMOVAL OF TAPE COUNTER

- A. Remove top cover and control panel.
- B. Remove counter drive belts from idler. Pull assembly.

SECTION 3 - MECHANICAL DISASSEMBLY PROCEDURE

- C. Remove 6AQ5 tube from socket.
- D. Remove 2 phillips head screws from rear of counter.
DO NOT REMOVE SCREWS FROM CHASSIS.

3.14 REMOVAL OF HYSTERESIS MOTOR

- A. Remove top cover panel.
- B. Remove drive puck and both rewind pucks.
- C. Unsolder motor leads from capacitor.
- D. Remove 2 screws holding motor from top side of transport base plate.

3.15 REMOVAL OF FLYWHEEL

- A. Remove top cover panel.
- B. Remove control panel.
- C. Remove capstan sleeve and pinch roller.
- D. The flywheel assembly rests on 4 posts, approximately 1-1/4" high, located at the 4 corners of the base plate. Remove the 4 screws holding this base plate to the 4 posts. Disconnect the 2 springs attached to the back of the base plate.
- E. The entire assembly can now be turned vertically and the fly-wheel slipped out.

NOTE: Refer to exploded diagram, p. 30, when performing this operation. When re-assembling, replace left front screw loosely to act as a pivot against the pinch roller tension spring.

3.16 REMOVAL OF INSTANT STOP LEVER ASSEMBLY

- A. Disconnect spring.
- B. Remove instant stop arm (Ref. A19).
- C. Remove snap washer from shaft.

3.17 REMOVAL OF TAKE-UP BRAKE ARM

- A. Remove brake pressure spring.
- B. Lift brake arm from slot.

3.18 DISASSEMBLY OF FORWARD/STOP/REWIND CAM ASSEMBLY

This operation will probably only be needed on rare occasions. It should be done only by an experienced mechanic.

- A. Remove take-up puck (Ref. A27).
- B. Remove take-up puck arm (Ref. A25).
- C. Remove reset spring (Ref. 114).
- D. Remove U-shaped cam holding shaft from bottom (Ref. 51).

NOTE: Please note position of different components while disassembling. This will facilitate re-assembling.

SECTION 4 - MECHANICAL ADJUSTMENT PROCEDURE

The mechanism of the Model 500 STERECORDER is so designed that there are no mechanical adjustments, such as brakes, tape tension, etc., necessary. The few mechanical adjustments which might be necessary after the transport has been disassembled and re-assembled are:

4.1 LINKAGE FROM RECORD BUTTON TO RECORD/PLAY SWITCH (SW1 & SW2) (page 33)

- A. Remove bottom cover.
- B. When depressing CH. 1 "RECORD" button, this linkage will activate the switch from left to right, changing the contacts to the position necessary for recording.
- C. Depress the CH. 1 "RECORD" button and place the mechanism in "FORWARD" position. This should hold the contacts in the necessary position.
- D. You may now adjust nut (Ref. 132) so that the contacts remain in the recording position after placing mechanism in "FORWARD" position and removing pressure from "RECORD" button.
- E. Repeat for CH. 2.

4.2 LINKAGE FROM FORWARD/STOP/PLAY ASSEMBLY TO AUTOMATIC AC SHUT-OFF ASSEMBLY

- A. Remove top cover panel and control panel.
- B. With transport in "FORWARD" position, adjust wire to allow mechanism to operate with tape in place. Check adjustment by cycling mechanism from "STOP" to "FAST FORWARD", "FORWARD" and "REVERSE".

4.3 MOTOR DRIVE PULLEY (Ref. 136 page 32)

- A. Remove top cover panel.
- B. Loosen set screw on pulley and adjust so that, in 7-1/2 ips the top of the large diameter is about 1/32" above the top of the drive puck (Ref. A23), and 1/32" below the bottom of the take-up puck (Ref. A27).

For brevity, parts numbers are omitted in text and reference numbers keyed to illustrations and parts list are used.

Please order by part number and description. Example:

A29 X00370-05-0 Idler Arm Assembly

SONY MODEL 500

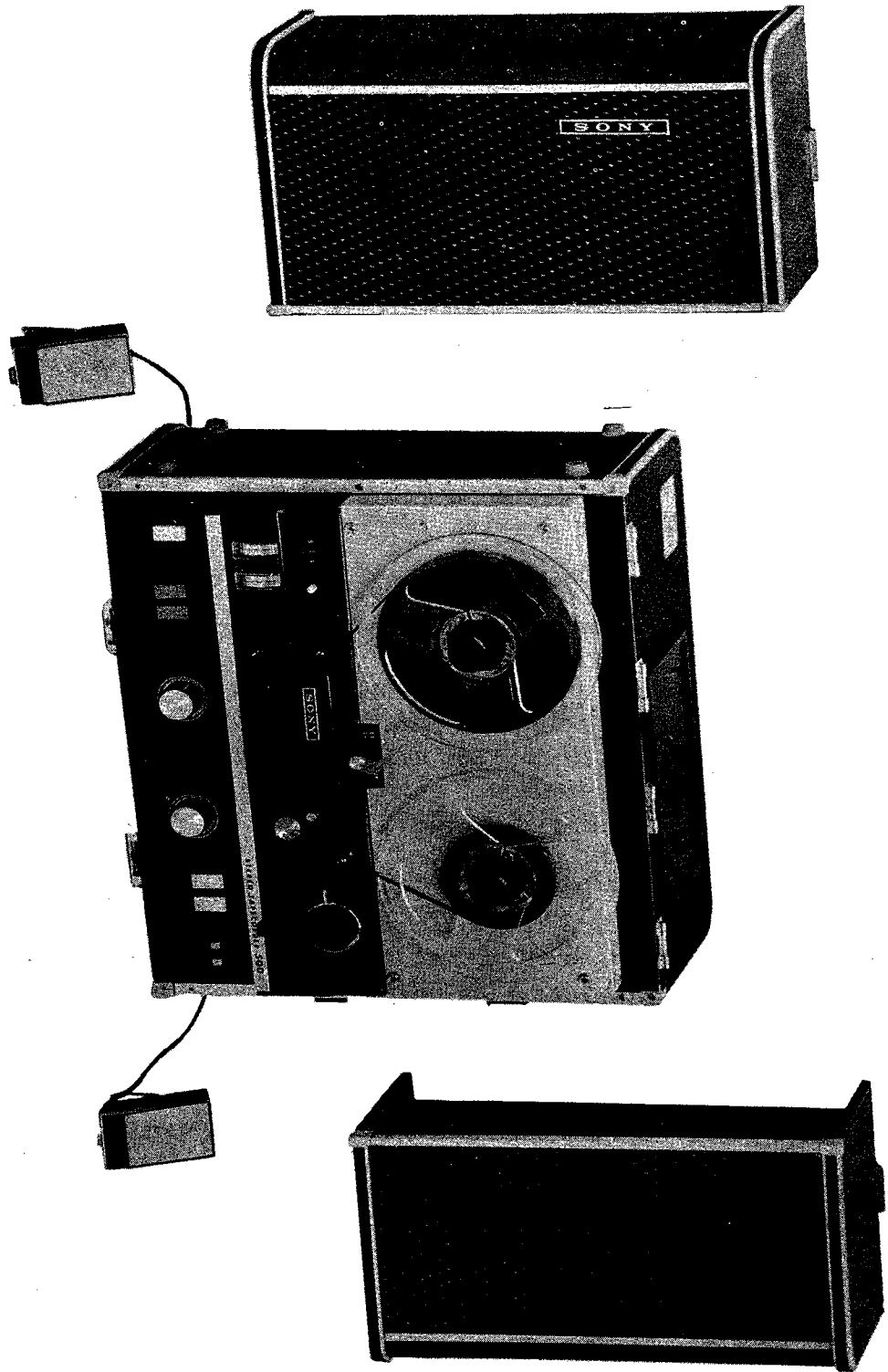

SUPERSCOPE
The Tapeway to Stereo

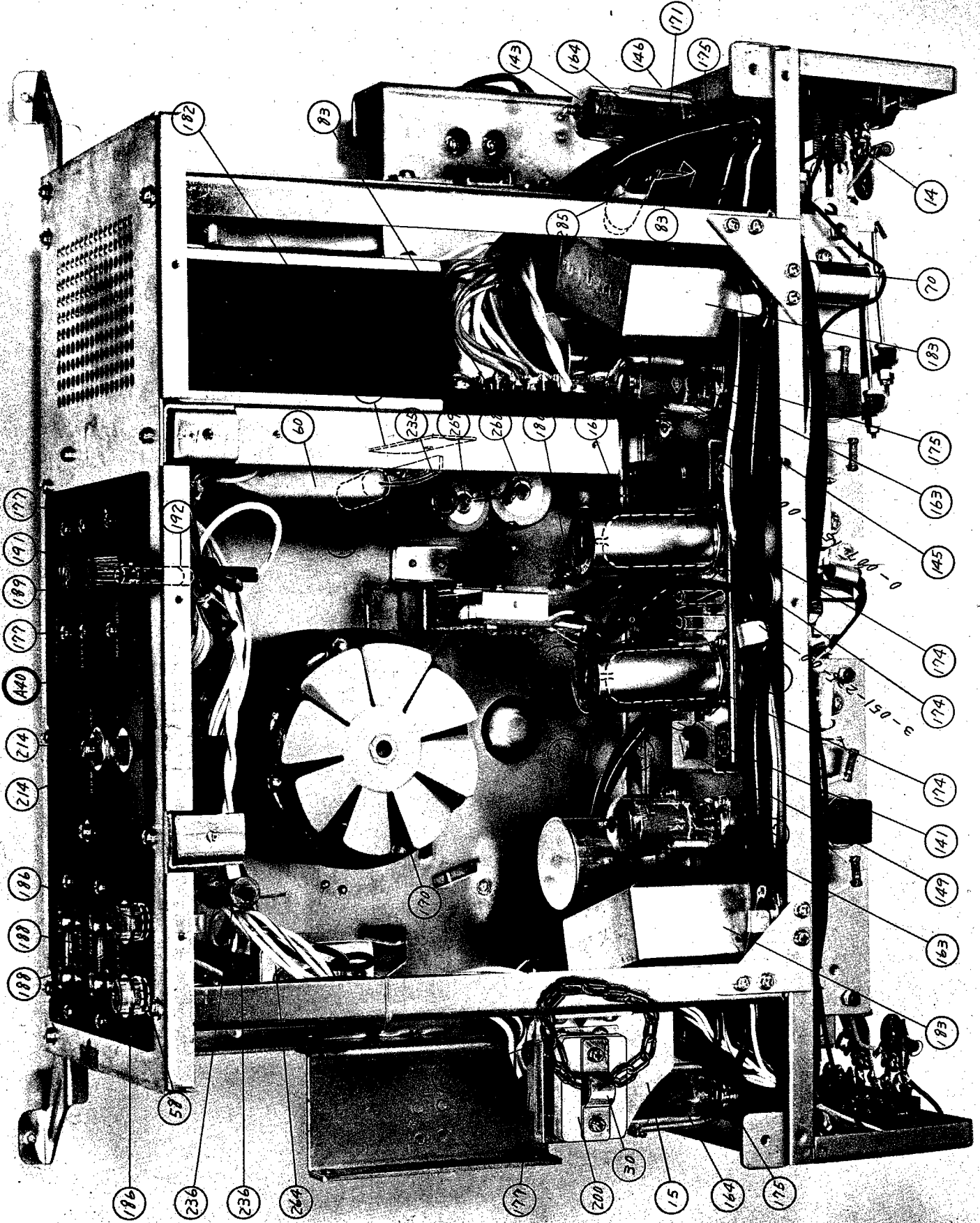

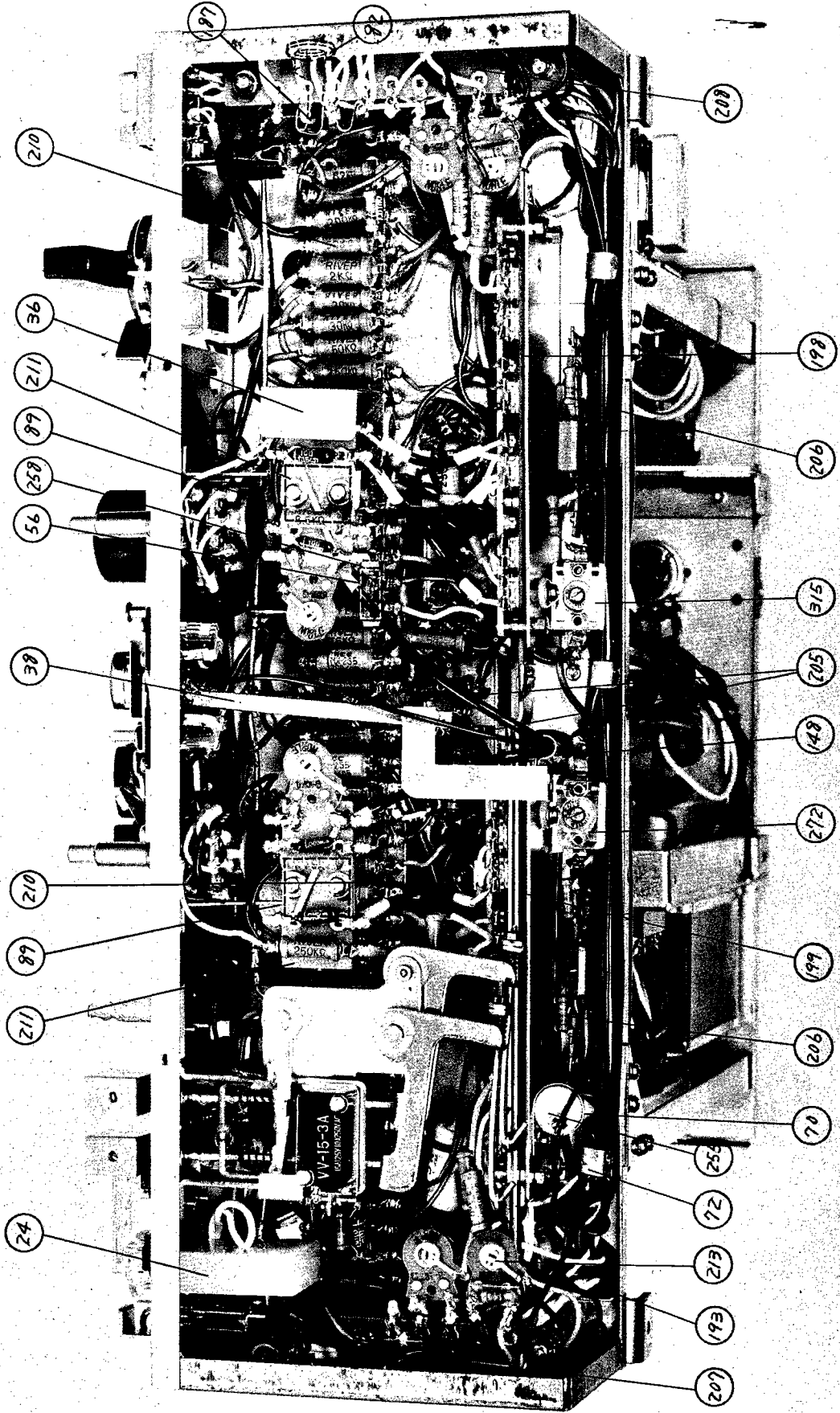

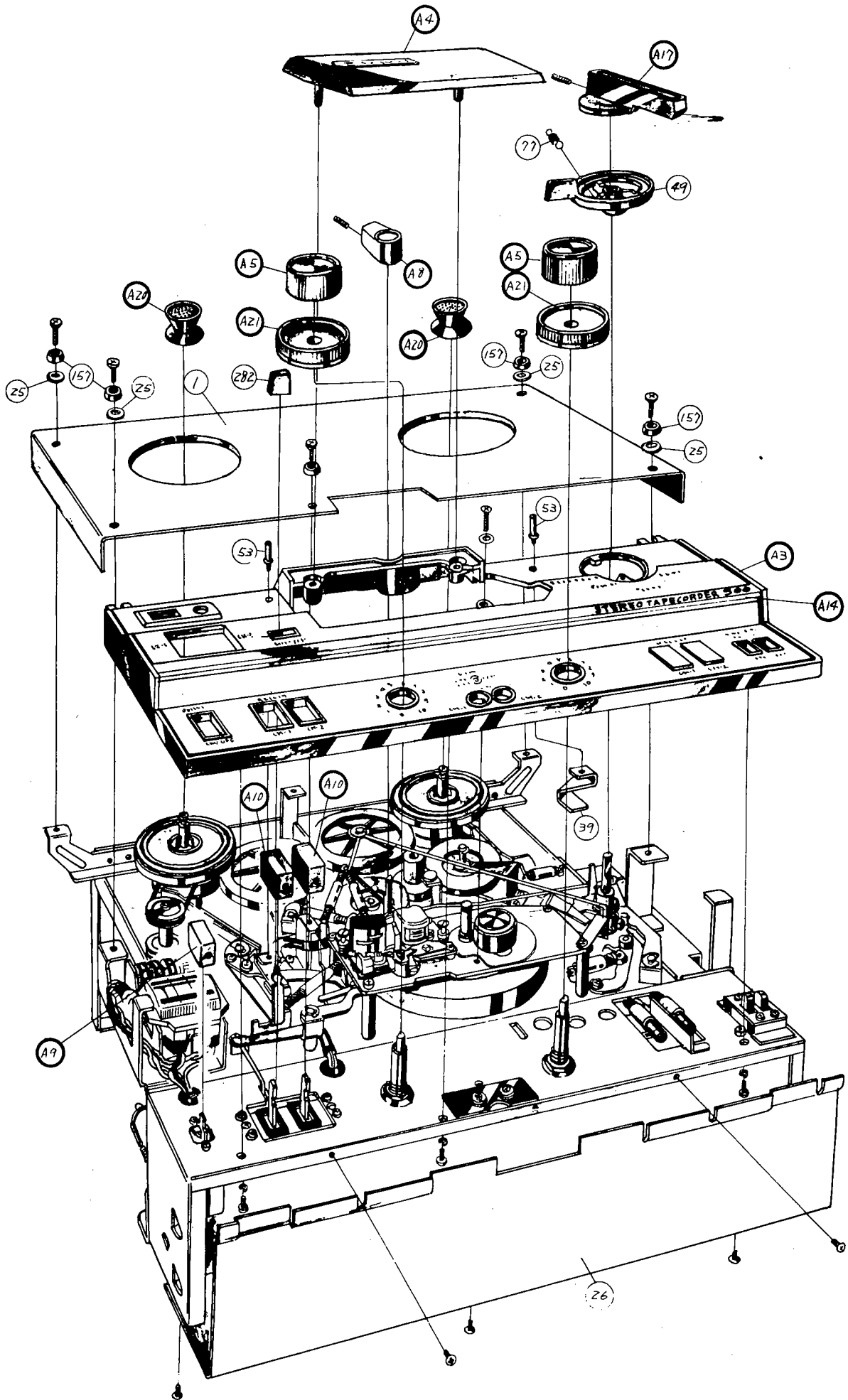

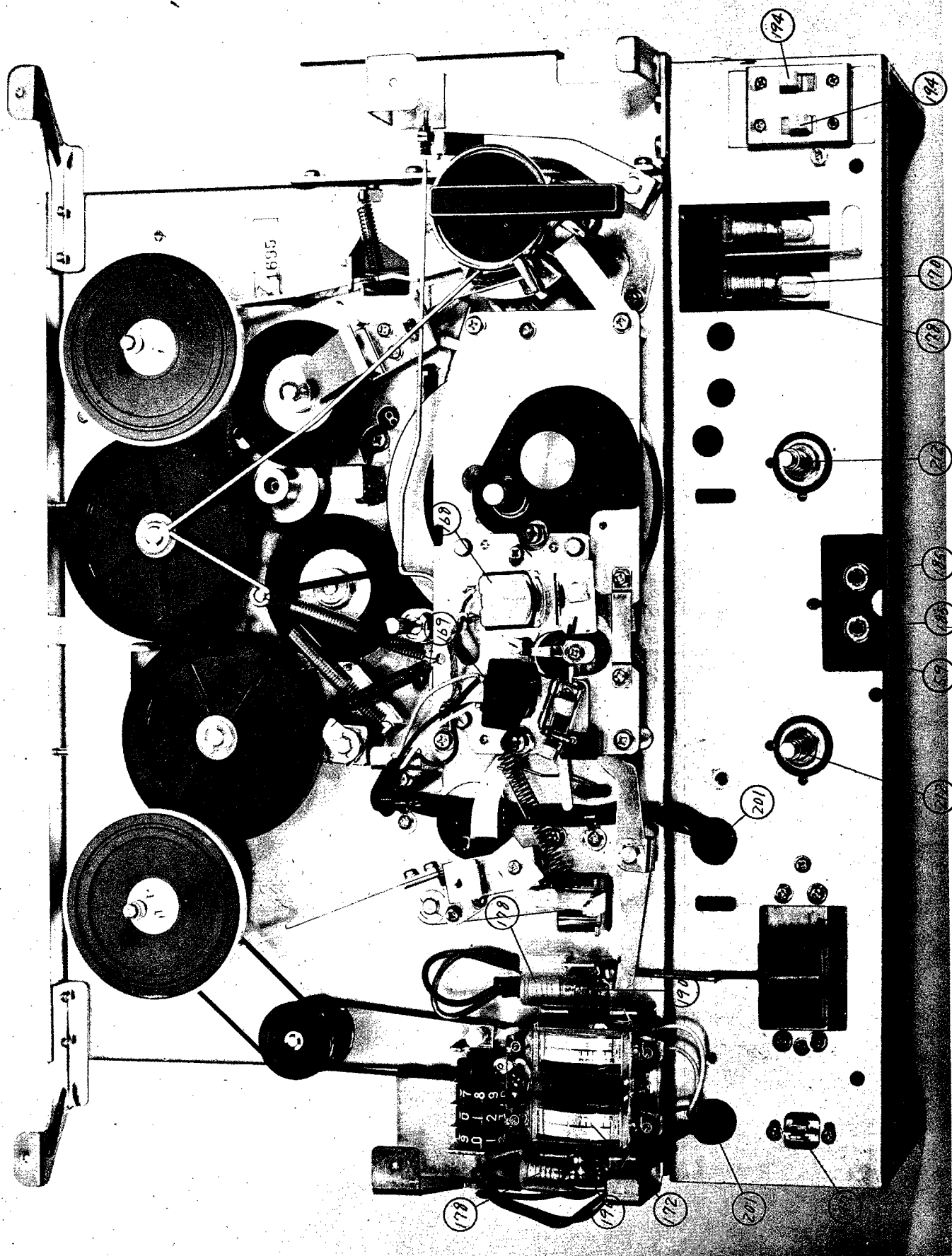

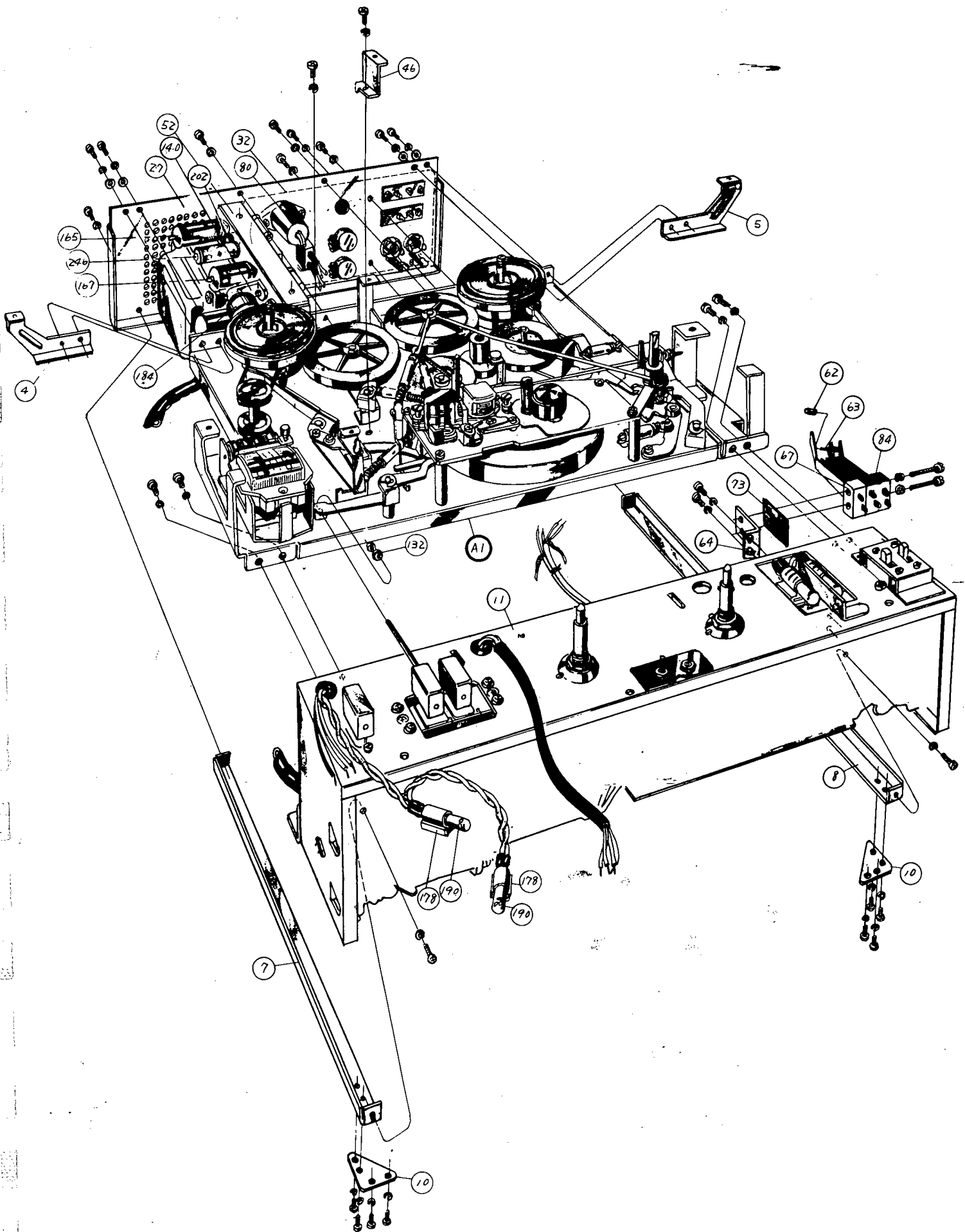

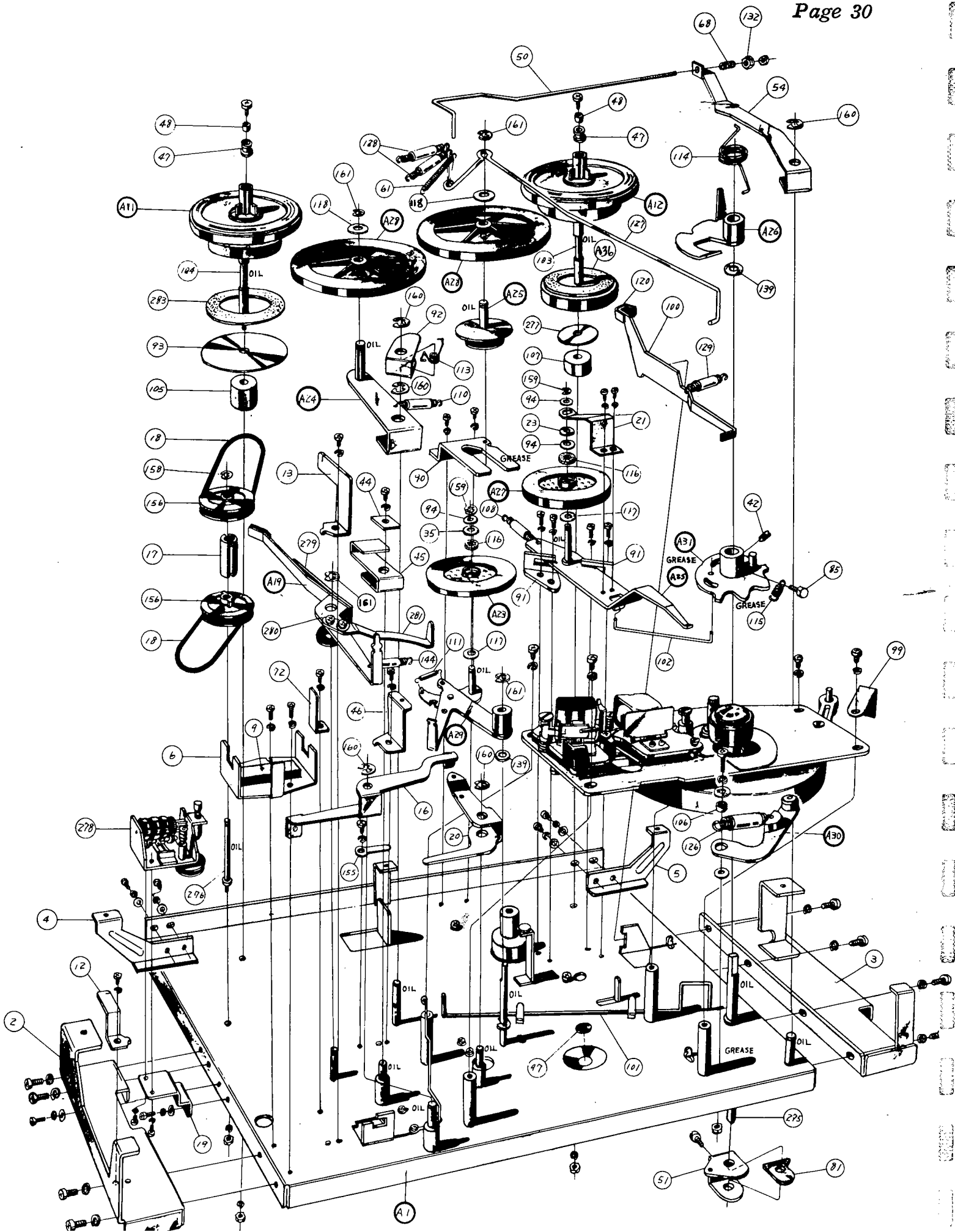

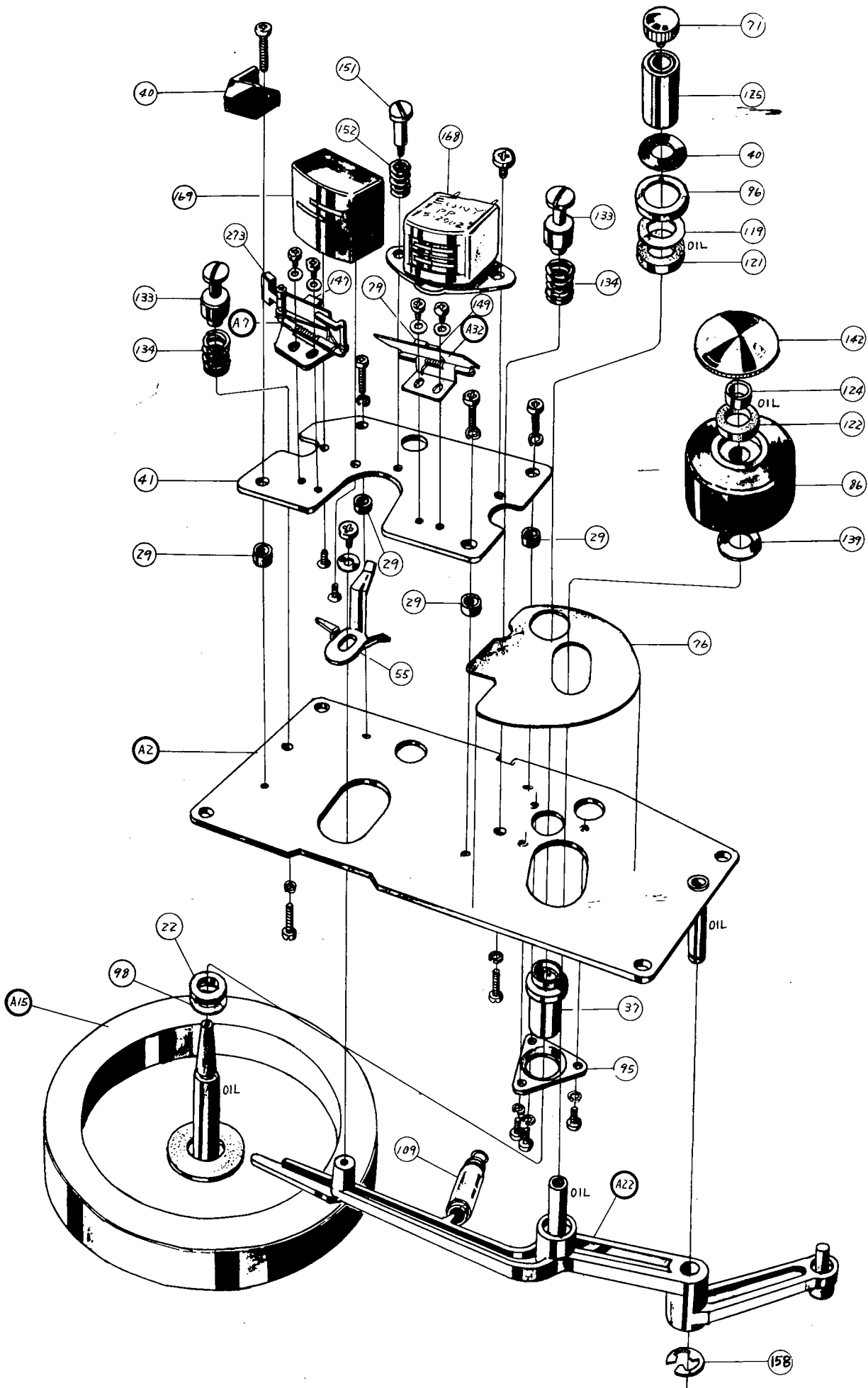

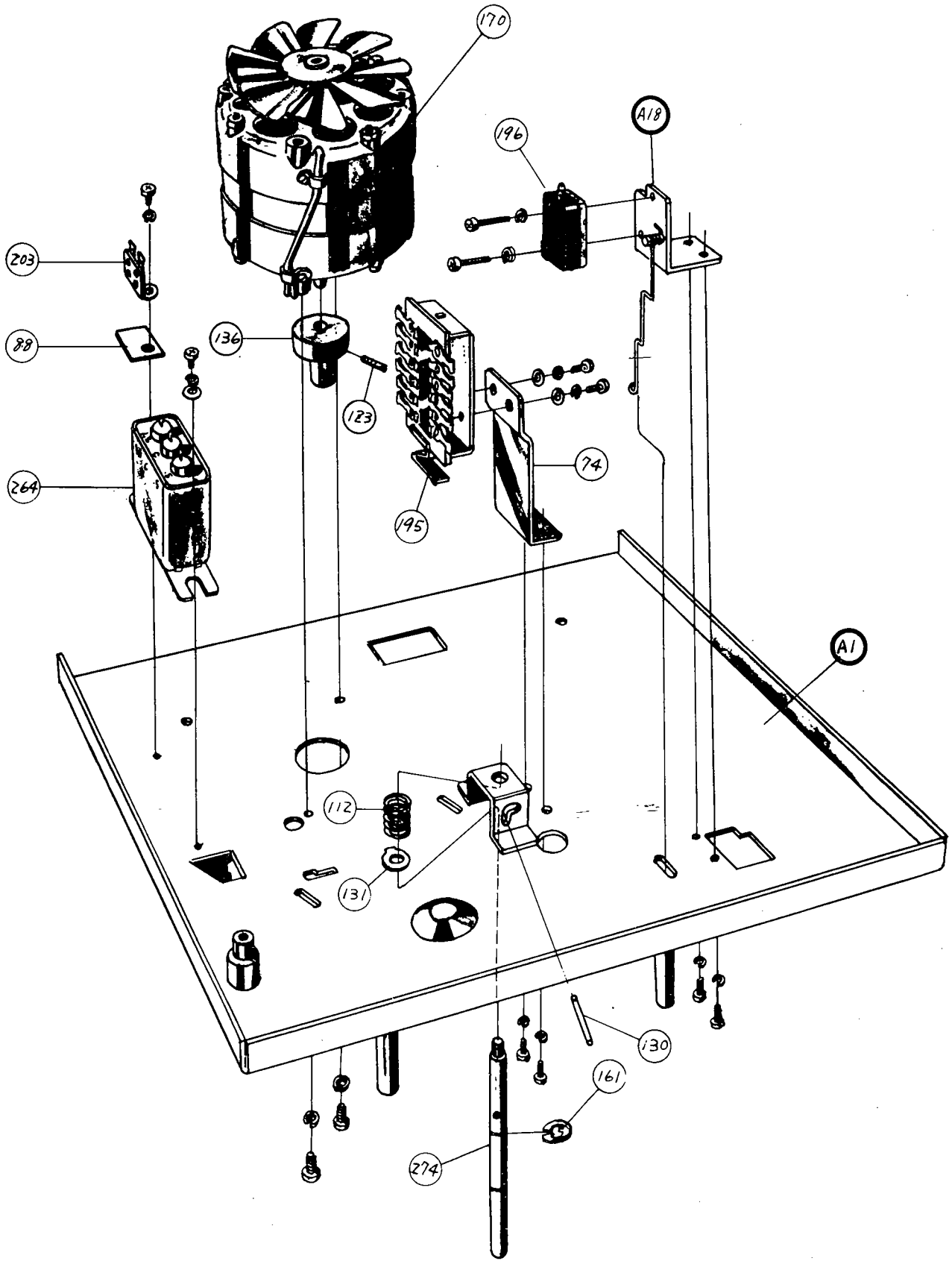

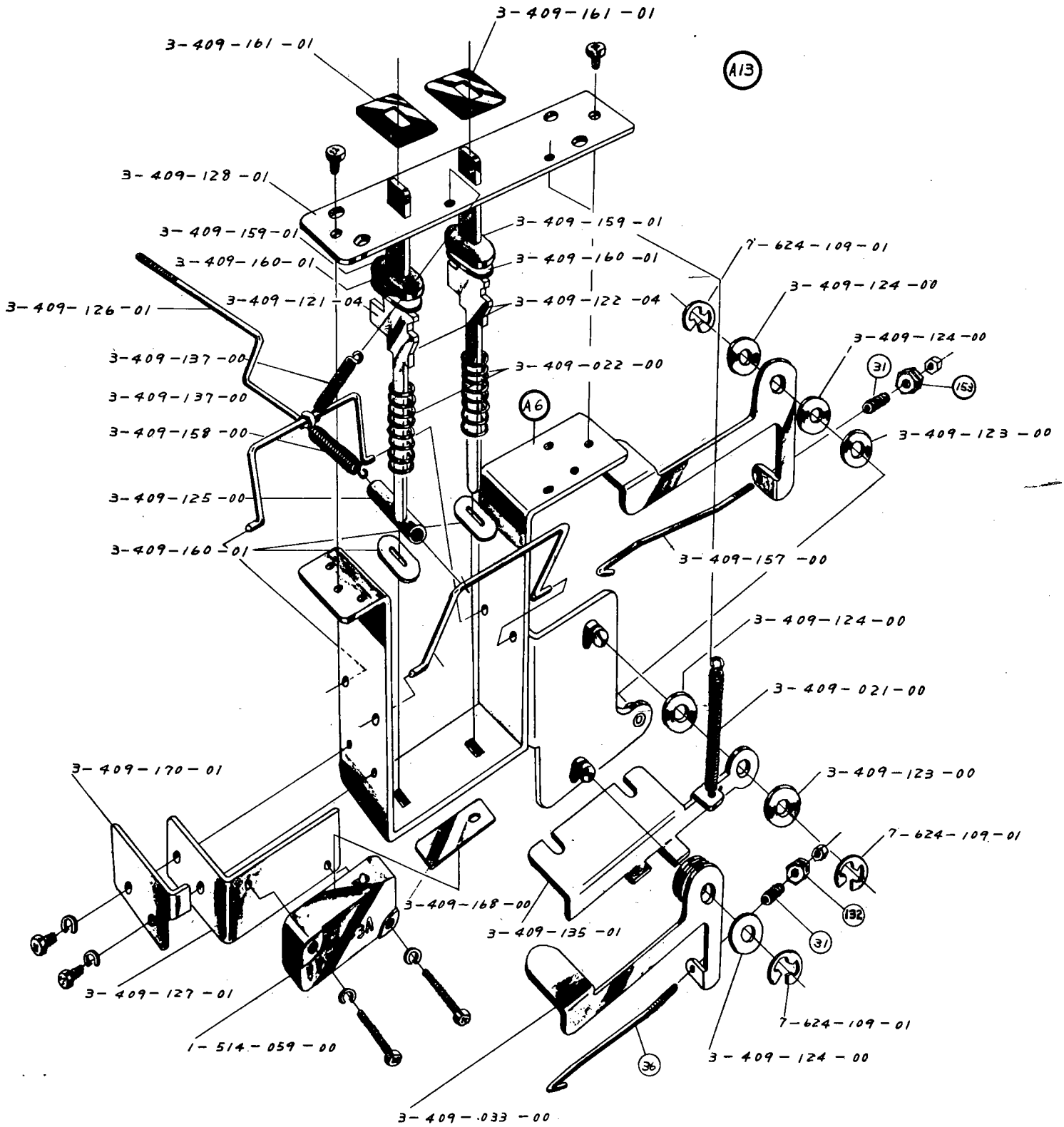

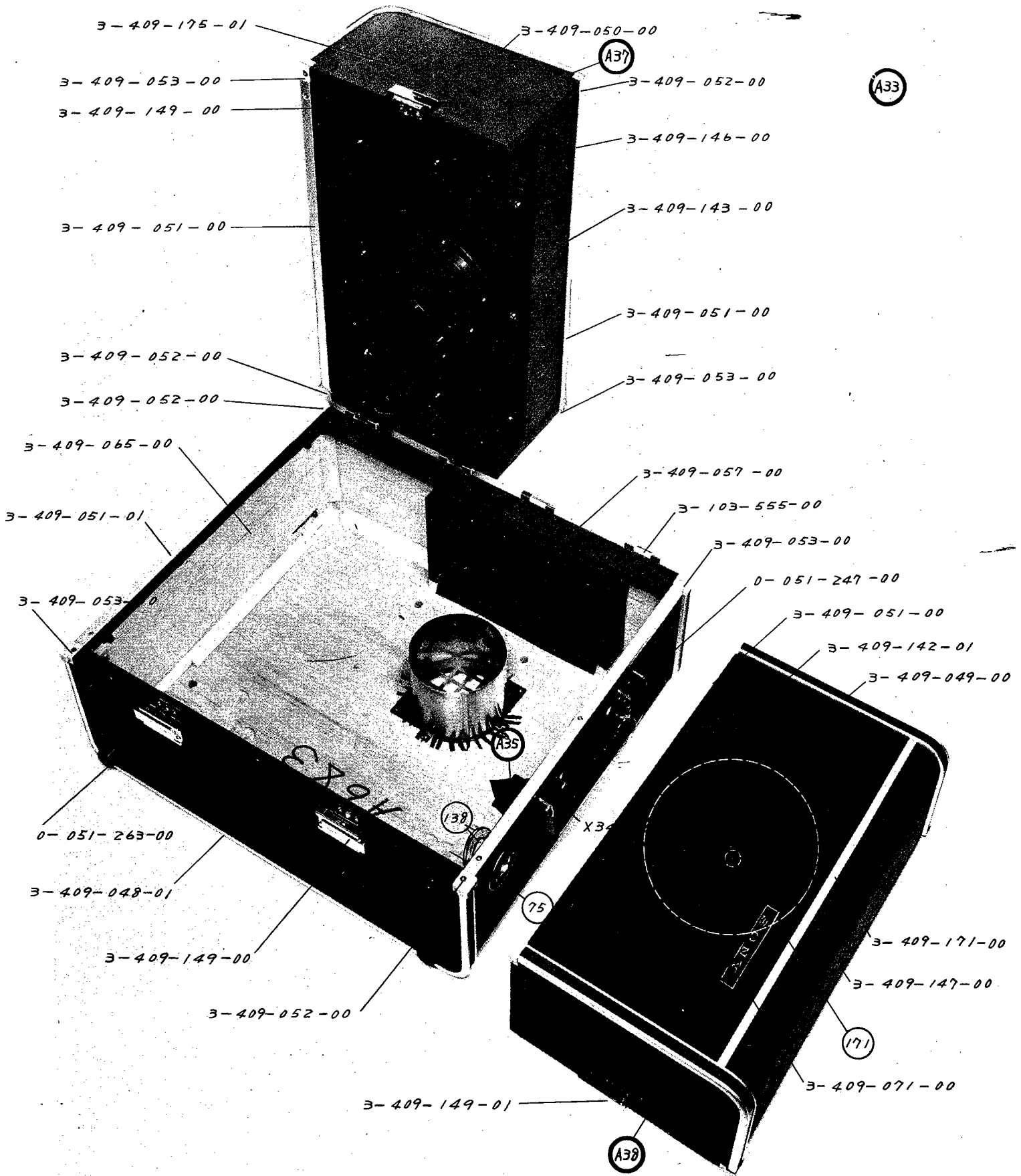

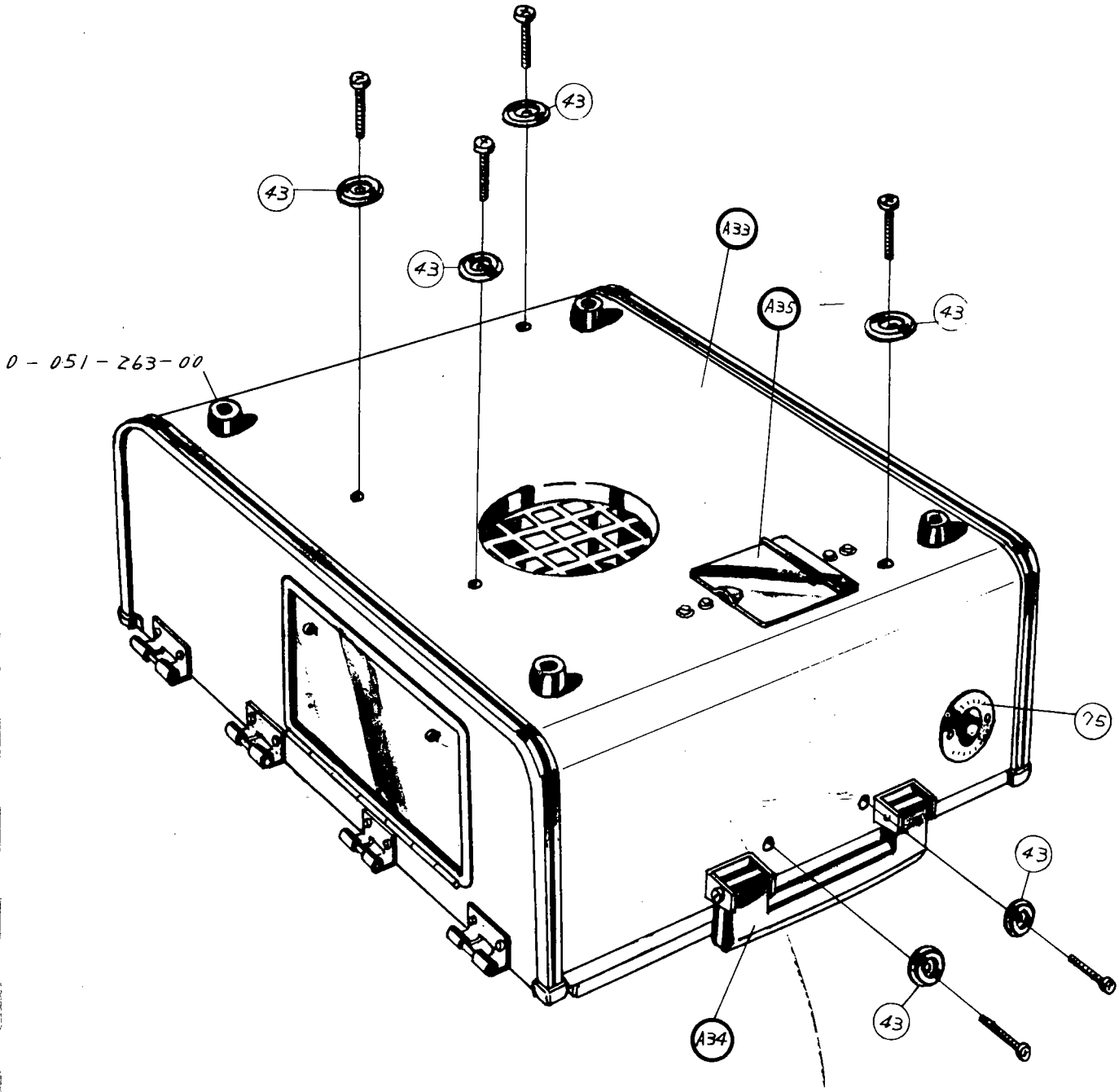

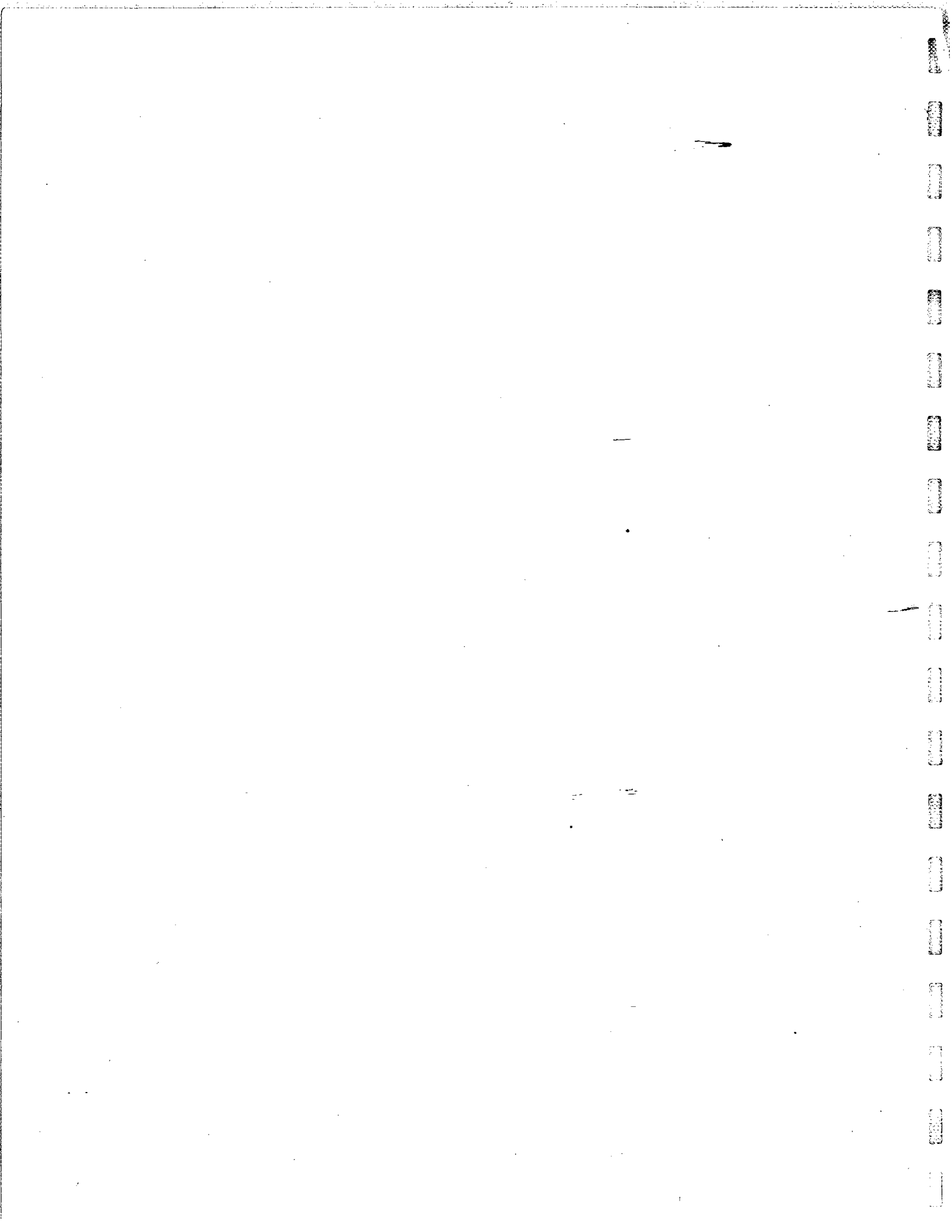

S T E R E C O R D E R500 M O D E L

<i>Ref. No.</i>	<i>Part No.</i>	<i>Description</i>	<i>Unit Price</i>
A1	X-34090-01-0	Base Plate Assembly	5.40
A2	X-34090-02-0	Head Deck Assembly	1.70
A3	X-34090-03-1	Control Panel Assembly	5.82
A4	X-34090-04-0	Head Cover Assembly	1.00
A5	X-34090-05-0	Volume Control Knob (Upper) Assembly	.85
A6	X-34090-09-1	Switch Mounting Plate Assembly	.75
A7	X-34090-11-0	Head Hinge Assembly	.85
A8	X-34090-12-1	Speed Selector Knob Assembly	.70
A9	X-34090-14-0	Power Switch Button Assembly	.30
A10	X-34090-15-0	Recording Switch Button Assembly	.60
A11	X-34090-16-02	Feed Reel Table Assembly	2.20
A12	X-34090-17-2	Take-Up Reel Table Assembly	2.20
A13	X-34090-18-2	Record Switch Assembly	3.66
A14	X-34090-19-0	Ornamental Strip Assembly	1.05
A15	X-34090-20-0	Capstan Shaft Assembly	4.85
A16	X-34090-21-0	Idler Plate Assembly	.42
A17	X-34090-22-0	Function Selector Knob Assembly	.90
A18	X-34090-23-0	Actuator Assembly	.35
A19	X-00270-17-0	Instant Stop Brake Assembly	.20
A20	X-34090-25-0	Reel Cap Assembly	.55
A21	X-34090-26-1	Volume Control Knob (B) (lower) Assembly	.50
A22	X-00270-02-0	Pinch Lever Assembly	.65
A23	X-00270-03-0	Capstan Idler Assembly	1.25
A24	X-00270-09-0	Rewind Idler Arm (C) Assembly	.42
A25	X-00270-10-0	Idler Shaft (C) Assembly	.30
A26	X-00270-13-0	Fast Forward Cam Assembly	.30
A27	X-00270-19-0	Take-Up Idler Assembly	1.25
A28	X-00270-25-0	Rewind Idler Assembly	.90
A29	X-00370-05-0	Idler Arm Assembly	.60
A30	X-00370-04-0	Stepper Arm Assembly	.30
A31	X-00510-65-01	Function Selector Cam Assembly	.90
A32	X-00510-66-00	Head Shield Plate Assembly	.36
A33	X-34090-06-0	Cabinet Assembly	32.00
A34	X-34090-08-0	Handle Grip Assembly	1.25
A35	X-31030-22-0	Bottom Lid Assembly	1.35
A36	X-34026-44-0	Take-Up Spindle Drum Assembly	.65
A37	X-34090-33-0	Cabinet Cover (left) Assembly	24.00
A38	X-34090-32-0	Cabinet Cover (right) Assembly	24.00

Prices contained in this Parts List are subject to change without notice.

All items are available only in quantities necessary for replacement in Sony products.

Any order for unduly large quantities will not be honored.

Ref. No.	Part No.	Description	Unit Price
1	3-409-003-01	Top Panel	4.75
2	-004-02	Panel Mounting Plate (left)	.40
3	-005-02	Panel Mounting Plate (right)	.60
4	-006-01	Panel Supporting Plate (left)	.15
5	-007-01	Panel Supporting Plate (right)	.15
6	-008-02	Level Meter Holding Bracket	.20
7	-009-00	Reinforcing Bracket (A)	.25
8	-010-00	Reinforcing Bracket (B)	.25
9	-024-01	Meter Holder	.10
10	-026-00	Triangle Bracket for Reinforcing Plate	.10
11	-043-03	Amplifier Chassis	4.56
12	-044-01	Pilot Lamp Mounting Plate (left)	.10
13	-054-00	Pilot Lamp Mounting Plate (right)	.10
14	-060-00	Reset Spring for Function Selector Switch	.10
15	-066-01	Defeat Socket Holding Plate	.30
16	-064-00	Lever for Push Button	.20
17	-087-00	Counter Pulley Spacer	.10
18	-088-00	Tape Index Counter Belt	.25
19	-089-02	Counter Mounting Plate	.10
20	-093-00	Automatic Shut-off Lever Stopper	.12
21	-097-02	Idler Retainer (A)	.20
22	-101-00	Nylon Washer (A)	.05
23	-102-00	Nylon Washer (B)	.05
24	-107-01	Switch Cover (for Power Switch)	.10
25	-108-00	Reel Panel Washer	.05
26	-129-02	Shield Plate (A) (front)	1.00
27	-131-01	Chassis Back Plate	1.32
28	-133-01	Spring for Record/Playback Pull Rod	.10
29	-139-00	Spacer for Head Deck	.10
30	-144-00	Short Circuit Plug	.10
31	-148-00	Chain	.15
32	-140-00	Connector Indicating Plate	.55
33	-157-00	Pull Rod (B) for Function Selector	.10
34	-162-01	Oil Absorber for Capstan	.05
35	-163-00	Idler Thrust Washer	.05
36	-164-01	Shield Plate (B)	.12
37	-165-00	Capstan Bearing	.75
38	-166-02	Shield Plate (C)	.20
39	-178-00	Panel Spacer (A)	.10
40	-180-00	Tape Guard	.12
41	-181-00	Head Mounting Plate	.78
42	-188-00	Function Cam Set Screw	.12
43	-191-00	Cabinet Washer	.10
44	-192-00	(Special) Washer (A)	.05
45	-194-00	Panel Spacer (C)	.10
46	-197-00	Panel Spacer (D)	.10

<i>Ref. No.</i>	<i>Part No.</i>	<i>Description</i>	<i>Unit Price</i>
47	3-409-201-00	Reel Cap Spacer (A)	.10
48	-202-00	Reel Cap Spacer (B)	.10
49	0-051-098-01	Fast Forward Knob	.60
50	-078-00	Pull Rod for Micro Switch	.10
51	-099-00	Bracket for Muting Switch Control	.12
52	-013-00	Power Supply Chassis	1.45
53	-063-01	Tension Lever Guide	.25
54	-076-00	Fast Forward Cam Selector Lever (A)	.40
55	-041-00	Tape Pad Shifter	.10
56	-109-00	Capacitor Shield Plate	.10
57	-110-00	Cushion Socket Sheet	.30
58	-113-00	Jack Spacer	.05
59	-119-00	Jack Escutcheon	.10
60	-206-00	Power Transformer Shield Plate	.40
61	-210-00	Spring for Pull Rod (A)	.10
62	-212-00	Muting Switch Spacer	.10
63	-213-00	Spacer Mounting Screw	.05
64	-214-00	Muting Switch Mounting Plate	.12
65	-217-00	6P Terminal Strip	.30
66	-218-00	9P Terminal Strip	.35
67	-219-00	Muting Switch (Black)	.15
68	-220-00	Pull Rod Spring (B)	.10
69	-221-00	Pad for Knob	.15
70	-233-00	Capacitor Holding Bracket	.10
71	-225-00	Capstan Set Screw	.12
72	-235-00	Wire Retainer	.10
73	-236-00	Leaf Switch Insulator	.05
74	-237-00	Equalizer Switch Mounting Plate	.15
75	-276-00	Escutcheon (B)	.75
76	-118-01	Decoration Plate for Pinch Roller	.10
77	-340-00	Fast Forward Spring	.10
78	-359-00	Spacer (A) for 46P Terminal Plate	.10
79	-363-00	Head Pad (Rec./PB.)	.05
80	-365-00	AC Socket Cover	.10
81	-368-00	Record Cam	.15
82	-370-00	Fiber for Binaural Monitor Jack	.05
83	-376-00	Specular Capacitor Fiber	.10
84	-379-00	Muting Switch S (Brown)	.36
85	-380-01	Function Selector Cam Set Screw	.10
86	-426-00	Pinch Roller (B)	1.25
87	-427-00	Lug Terminal Insulator (A)	.05
88	-428-00	Lug Terminal Insulator (B)	.05
89	-199-00	Insulating Fiber for 8P Lug	.05
90	0-027-019-00	Idler Guide Support	.12
91	-020-00	Idler Guide	.10

Ref. No.	Part No.	Description	Unit Price
92	0-027-029-00	Brake Block	.10
93	-034-00	Feed Spindle Deck	.10
94	-035-00	Thin Washer 5¢	.05
95	-036-00	Bearing Retainer	.10
96	-038-00	Bearing Cover	.10
97	-040-00	Thrust Bearer (Vulcanized Fiber)	.05
98	-058-00	Washer for Adjustable Screw	.05
99	-018-00	Fast Forward Cam Stopper	.10
100	-078-00	Brake Lever	.12
101	-111-00	Push Rod (A)	.12
102	-113-00	Pull Rod	.05
103	-119-00	Take-Up Spindle	.25
104	-120-00	Feed Spindle	.25
105	-121-00	Feed Spindle Spacer	.20
106	-134-00	Stepper Shaft	.05
107	-180-00	Take-Up Spindle Spacer	.10
108	-191-00	Helical Spring (A)	.05
109	-193-00	Helical Spring (D)	.05
110	-194-00	Helical Spring (E)	.05
111	-197-00	Helical Spring (H)	.05
112	-198-00	Speed Selector Shaft Spring	.10
113	-200-00	Brake Block Spring	.10
114	-201-00	Fast Forward Reset Spring	.10
115	-207-00	Reset Spring	.05
116	-216-00	Oil Absorber 5¢	.05
117	-220-00	Paper Washer 5¢	.05
118	-221-00	Paper Washer 5¢	.05
119	-230-00	Oil Retainer Cover	.05
120	-249-00	Brake Felt	.05
121	-250-00	Oil Retainer	.05
122	-479-00	Pinch Roller Oil Absorber	.05
123	-170-00	Set Screw for Motor Pulley	.05
124	-181-00	Pinch Roller Spacer	.10
125	-483-02	Capstan (60 c/s)	.45
126	0-037-018-00	Stepper Spring	.10
127	-028-00	Rewind Control Rod (B)	.15
128	-040-00	Idler Spring	.10
129	-240-00	Brake Spring	.10
130	-247-00	Speed Selector Shaft Pin	.10
131	-248-00	Speed Selector Shaft Washer	.10
132	-249-00	Split Nut	.10
133	-406-00	Tape Guide S	.20
134	-407-00	Tape Guide Spring	.12
135	-020-00	Instant Stop Lever Block	.10
136	-029-00	Motor Pulley	1.05

<i>Ref. No.</i>	<i>Part No.</i>	<i>Description</i>	<i>Unit Price</i>
137	0-041-116-00	<i>Terminal Strip (A)</i>	.05
138	-121-00	<i>Back Plate for Mic. Jack Escutcheon</i>	.15
139	0-006-095-00	<i>Thrust Washer</i>	.05
140	0-045-040-00	<i>Oscillation Transformer Mounter</i>	.10
141	0-049-136-00	<i>Rubber Cushion</i>	.12
142	-032-00	<i>Pinch Roller Set Screw</i>	.50
143	0-007-159-00	<i>Vacuum Tube Clamp</i>	.10
144	-229-00	<i>Helical Spring (I)</i>	.05
145	-238-00	<i>Vacuum Tube Hold Spring (A)</i>	.05
146	-239-00	<i>Vacuum Tube Hold Spring (B)</i>	.05
147	-254-00	<i>Tape Pad (for Erase Head)</i>	.05
148	-313-00	<i>Wire Retainer</i>	.05
149	-985-00	<i>Cushion Retainer for Vacuum Tube</i>	.12
150	-986-00	<i>Cushion Retainer Washer for Vacuum Tube</i>	.05
151	3-005-001-60	<i>Record Playback Head Fix Screw</i>	.10
152	-001-70	<i>Record Playback Head Adjusting Spring</i>	.10
153	0-056-312-00	<i>Head Pad (Playback Head, Small)</i>	.05
154	3-402-906-00	<i>Fiber Insulator for Oscillation Transformer</i>	.05
155	3-405-539-00	<i>Wire Retainer</i>	.05
156	3-407-040-00	<i>Counter Belt Pulley</i>	.20
157	3-412-059-00	<i>Washer for Reel Panel Fix Screw</i>	.10
158	7-624-107-01	<i>Retainer Ring E-3. 2</i>	1.35
159	-108-01	<i>Retainer Ring E-4</i>	1.90
160	-109-01	<i>Retainer Ring E-5</i>	1.62
161	3-005-010-00	<i>Retaining Ring (for 6¢ shaft)</i>	1.62
162	7-623-508-01	<i>Lug 3¢</i>	.35

Ref. No.	Symbol No.	Part No.	Description	Unit Price
163	V102 & 202	1-525-007-00	Vacuum Tube 6AU6	1.35
164	V103 & 203	-010-00	Vacuum Tube 6AQ5	1.65
165	V2	-019	Vacuum Tube 6CA4	1.25
166	V101 & 201	-020	Vacuum Tube 12AX7 or 12AD7	2.15
167	V1	-033	Vacuum Tube 12BH7A	2.15
168	R.P.H.	8-820-400-01	Record/Playback Head PP15-2902S	18.40
169	E.H.	8-829-229-02	Erase Head EF13-2902	7.40
170	M	8-831-134-00	Motor HC-134	26.85
171		1-502-082-11	Speaker 10cm	5.12
172	VU101 & 201	1-524-015-12	V. U. Meter	8.45
173		1-531-501-00	Copper-Oxide Rectifier	.75
174	for 12AD7	1-526-016-02	Vacuum Tube Socket (9 pin)	.60
175	for 6AU6 & 6AQ5	1-526-005-00	Vacuum Tube Socket (7 pin)	.20
176	for 12BH7 & 6CA4	-009-00	Vacuum Tube Socket (9 pin)	.20
177	CN1. 4 & 2. 5	1-509-015-01	AC Socket	.30
178	PL101, 201 & PL1-2	1-517-003-00	Pilot Lamp Socket	.15
179	D	1-431-018-01	Dummy Coil	.40
180	L102 & L202	-006-00	Hum Buck Coil	.20
181	L101 & L201	1-421-002-00	Choke Coil	.60
182	T2	1-441-017-00	Power Transformer	12.35
183	T101 & T201	1-427-041-02	Output Transformer	4.25
184	T1	1-433-009-00	Oscillation Transformer	1.60
185	J102 & J202	1-507-028-00	Miniature Microphone Jack	.25
186	J104 & J204	1-507-016-00	Ext. Jack (Type E)	.50
187	J1	-106-00	Jack for Stereo Earphone	1.00
188	J101, 201, 103 & 203	-154-00	Pin Jack 2P (RCA Type)	.60
189	CN3	1-509-013-00	(Special) AC Socket (UL Standard)	.55
190		1-518-011-00	Pilot Lamp 6-8V (Clear)	.10
191	F	1-533-012-01	Fuse Holder	.50
192		1-532-007-00	Fuse 1.5A	.10
193		1-599-006-11	Rubber Bushing	.05
194	SW4 & SW5	1-513-091-01	Slide Switch 2-2-2 (SW4, PB. Low Boost) (SW5, Speaker ON/OFF)	.70
195	SW3	-081-00	Push Button Switch 0-4-2	1.15
196	SW10	1-514-039-00	Micro Switch Type M8-1 125V 5A (Auto Stop)	1.35
197	SW9	-080-11	Power ON/OFF Switch	1.15
198	SW2	1-513-080-00	Record/Playback Switch	2.55
199	SW1	-180-11	Record/Playback Switch	2.45
200		1-506-011-01	Short-Circuiting Plug	.36

Ref. No.	Symbol No.	Part No.	Description	Unit Price
201		1-599-003-00	Rubber Bushing 10M/M ϕ	.05
202		-002-00	Rubber Bushing 8M/M ϕ	.05
203		1-536-005-00	Terminal Strip (1L-1P)	.05
204		-007-00	Terminal Strip (1L-4P)	.10
205		-028-00	Terminal Strip (1L-2P)	.05
206		1-536-008-00	Terminal Strip (2L-5P)	.10
207		-025-00	Terminal Strip (5P)	.10
208		-026-00	Terminal Strip (9P)	.10
209		-014-00	Terminal Strip (1L-3P)	.10
210		-023-00	Terminal Strip (46P)	.55
211		-024-00	Terminal Strip (8P)	.10
212	R101, 201, 114 & 214	1-221-110-00	Potentiometer 500KA (dual)	1.90
213	R107, 207, 135, 235, 136 & 236	-312-00	Adjustable Resistor 17L 10K ohms	.25
214	R7, 8	1-221-072-00	Hum Balancer 30 ϕ 300 ohms	.50
215	R133, 233	1-203-133-00	Carbon Resistor 100 ohms RD1/4L $\pm 10\%$.10
216	R103, 203	-930-00	Carbon Resistor 5M ohms RD1/2 $\pm 10\%$.10
217	R110, 210, 123 223, 130 & 230	-723-00	Carbon Resistor 500K ohms $\pm 10\%$.10
218	R102, 202, 125, 225, 104, 204, 118 & 218	-724-00	Carbon Resistor 250K ohms $\pm 10\%$.10
219	R112, 212, R4 & R5	-318-00	Carbon Resistor 100K ohms $\pm 10\%$.10
220	R108 & 208	-932-00	Carbon Resistor 75K ohms $\pm 10\%$.10
221	R121 & 221	-926-00	Carbon Resistor 200K ohms $\pm 10\%$.10
222	R122 & 222	-931-00	Carbon Resistor 62K ohms $\pm 10\%$.10
223	R106, 206, 126 & 226	-548-00	Carbon Resistor 50K ohms $\pm 10\%$.10
224	R115, 215, 124 & 224	-088-00	Carbon Resistor 30K ohms $\pm 10\%$.10
225	R119 & 219	-917-00	Carbon Resistor 100 ohms $\pm 10\%$.10
226	R111, 211, 120 & 220	-922-00	Carbon Resistor 1.5K ohms $\pm 10\%$.10
227	R138 & 238	-924-00	Carbon Resistor 18K ohms $\pm 10\%$.10
228	R137 & 237	-041-00	Carbon Resistor 1.5K ohms $\pm 5\%$.10
229	R132 & 232	-793-00	Carbon Resistor 2K ohms RD3/4L $\pm 10\%$.10
230	R2 & R3	-074-00	Carbon Resistor 10K ohms RD1/2L $\pm 10\%$.10
231	R139 & 239	-518-00	Carbon Resistor 600 ohms RD1/2L	.10
232	R9	-577-00	Carbon Resistor 200 ohms RD1/2L	.10
233	R105 & 205	-923-00	Carbon Resistor 8.5K ohms RD1/2L $\pm 5\%$.10
234	R104 & 204	-905-00	Carbon Resistor 250K ohms RD1/2L $\pm 10\%$.10
235	R1	-578-00	Carbon Resistor 3.5K ohms RD2L $\pm 10\%$.10
236	R140 & 240	-579-00	Carbon Resistor 8 ohms RD2L	.15

Ref. No.	Symbol No.	Part No.	Description	Unit Price
237	R131 & 231	1-203-580-00	Carbon Resistor 250 ohms RD2L	.10
238	R134 & 234	-894-00	Carbon Resistor 3.3K ohms RD2L+5%	.10
239	R142 & 242	-018-00	Carbon Resistor 220 ohms RD1/4L+5%	.10
240	R127 & 227	-104-00	Carbon Resistor 150K ohms RD1/4L	.10
241	R113 & 213	-114-00	Carbon Resistor 330K ohms RD1/4L	.10
242	R109 & 209	-125-00	Carbon Resistor 82K ohms RD1/4L	.10
243	R116, 216, 117, 217, 129 & 229	-812-00	Carbon Resistor 180K ohms RD1/4L	.10
244	R128 & 228	-110-00	Carbon Resistor 270K ohms RD1/4L	.10
245	R141 & 241	1-207-007-00	Wire Wound Resistor 2 ohms 1/2W+10%	.20
246	R6	1-205-187-00	Enameled Resistor 1K ohms 16W+10%	.75
247	C115 & 215	1-109-001-00	Mica Capacitor 50PF 400WV+10%	.10
248	C118 & 218	-053-00	Mica Capacitor 100PF 400WV+10%	.10
249	C107 & 207	1-109-059-00	Mica Capacitor 750PF 400WV+5%	.20
250	C121 & 221	-041-00	Mica Capacitor 150PF 400WV+5%	.15
251	C4, C106, 206	-042-00	Mica Capacitor 300PF 400WV+5%	.15
252	C6, 7 & 8	-034-00	Mica Capacitor 0.002uF 400WV+5%	.25
253	C120 & 220	1-115-046-00	Oil Filled Tubular Capacitor 0.05uF 400WV+20%	.15
254	C14	-043-00	Oil Filled Tubular Capacitor 0.25uF 600WV+20%	.45
255	C1	-050-00	Oil Filled Tubular Capacitor 0.1uF 400WV+20%	.50
256	C104 & 204	1-105-171-12	Mylar Capacitor MX 0.015uF 100V+5%	.20
257	C103, 203, 110 & 210	-047-12	MX 0.05uF 200V+20%	.20
258	C101 & 201	-015-13	Mylar Capacitor PMX 0.1uF 100V+20%	.20
259	C119 & 219	-034-12	Mylar Capacitor MX 0.02uF 100WV+10%	.10
260	C105 & 205	-032-12	Mylar Capacitor MX 0.002uF 100WV+10%	.10
261	C114 & 214	-019-12	Mylar Capacitor MX 0.04uF 100V+10%	.15
262	C123 & 223	-016-11	Mylar Capacitor MFL 0.001uF 100V+10%	.10
263	C117 & 217	-017-12	Mylar Capacitor MX 0.01uF 100WV+10%	.10
264	C5	1-117-008-00	MP Capacitor 0.5uF 250V+20%	.35
265	C108, 208 111 & 112	1-119-036-00	Electrolytic Capacitor 50uF 6WV	.15
266	C122, 222	-037-00	Electrolytic Capacitor 25uF 15WV	.15
267	C112, 212, 116 & 216	-050-00	Electrolytic Capacitor 3uF 350WV	.20
268	C10	-033-00	Electrolytic Capacitor 40uF 350WV	1.00
269	C9	-032-00	Electrolytic Capacitor 40uF 400WV	.70
270	C11	1-125-016-00	Electrolytic (Block) Capacitor 20uF x 4 450WV	1.80
271	C102, 202, 124, 224, 109 & 209, 113 & 213	-034-11	Electrolytic (Block) Capacitor 10uF x 4 350WV	1.00

Ref. No.	Symbol No.	Part No.	Description	Unit Price
272	C2 & 3	1-141-008-01	Trimmer Capacitor	.55
273		3-409-151-00	Head Pad for Tape Guide	.05
274		0-027-131-00	Speed Selector Shaft	.50
275		0-051-081-00	Cam Shaft	.35
276		3-409-086-00	Counter Pulley Shaft	.12
277		0-027-022-00	Idler Disc	.10
278		Y-20165-01-0	Tape Index Counter VI	4.85
279		0-027-061-00	Auxiliary Plate for Instant Stop Brake Arm	.10
280		3-409-176-00	Instant Stop Lever	.40
281		0-037-020-00	Pinch Lever Shifter	.10
282		3-406-769-00	Instant Stop Lever Knob	.10
283		0-027-215-00	Friction Felt (for Take-Up Reel Table)	.10
284	C12 & 13	1-113-010-00	MP Capacitor 1.5 - 0.5uF	1.45

Addenda for Model 500-A Mechanical Parts

Ref. No.	Part No.	Description	Price
A1	X-34090-01-3	Base Plate Assembly	5.40
A14	X-34090-19-3	Ornamental Strip	1.05
A33	X-34090-06-6	Cabinet Assembly (U. S. A.)	30.00
A38	X-34090-32-5	Speaker Box (Right)	16.00
A37	X-34090-33-5	Speaker Box (Left)	16.00
A35	X-31030-22-4	Connector Lid	1.25
A35	3-409-048-01	Cabinet Sash (A)	.95
A35	3-409-051-01	Cabinet Sash (D)	.45
A35	3-409-052-04	Plastic Sash Cover (A)	.10
A35	3-409-053-04	Plastic Sash Cover (B)	.10
A7	X-34090-11-4	Head Hinge Assembly	.85
A8	X-34090-12-9	Speed Selector Knob Assembly	.70
A10	X-34090-15-2	Record Button Assembly	.60
A11	X-34090-48-1	Supply Reel Table Assembly	2.20
A12	X-34090-49-1	Take-up Reel Table Assembly	2.20
A13	X-34090-18-3	Rec./P.B. Switch Mechanism Assembly	3.65
A16	X-34090-21-1	Take-up Idler Plate Assembly	.42
A20	X-34090-35-1	Reel Cap	.55
A36	X-34090-37-1	Take-up Spindle Drum Assembly	.65
283	3-409-218-01	Felt (Top)	.10
A5	X-34090-38-1	Volume Knob (Upper) Assembly	.85
A21	X-34090-39-0	Volume Knob (Lower) Assembly	.50
A2	X-34090-41-1	Head Deck Assembly	1.00
A4	X-34090-42-2	Head Cover Assembly	1.00
A18, 196	X-34090-43-2	Automatic Shut-Off Switch Lever	.35
A25	X-00270-10-1	Rewind Idler Shaft (Right) Assembly	.30
A26	X-00270-13-1	Fast Forward Cam Assembly	.30
86	X-34090-56-0	Pinch Roller (B) Assembly	1.50
	3-409-003-02	Reel Panel	4.75
	3-409-005-03	Panel Holding Plate (Right Medium)	.60
	3-409-008-03	VU Meter Holding Bracket	.20
11	3-409-043-06	Amplifier Chassis	4.56
12	3-409-044-02	Pilot Lamp Holding Bracket (Left)	.10
14	3-409-060-01	Reset Spring for Slide Switch	.10
21	3-409-097-03	Pressure Plate for Take-up Idler	.20
23	3-409-102-01	Nylon Washer (B) for Flywheel Shaft	.05
25	3-409-108-01	Nylon Washer for Reel Panel Mount	.05
26	3-409-129-03	Shield Plate (A)	1.00
27	3-409-131-03	Chassis Back Plate	1.32
32	3-409-140-04	Connection Indicating Panel	.55
30	3-409-144-00	Chain Clamp for Interlock Plug (for U. S. A. only)	.55
	3-409-208-00	Speaker Felt (A)	.30
	3-409-204-00	Cover for Back Panel	.05
	3-409-209-00	Speaker Felt (B)	.15
52	0-051-013-02	Chassis for Power Supply Block	1.50

<i>Ref. No.</i>	<i>Part No.</i>	<i>Description</i>	<i>Price</i>
	0-051-063-01	<i>Tension Lever Guide</i>	.25
	0-051-078-00	<i>Pull Rod (A)</i>	.10
	0-051-098-02	<i>Fast Forward Knob</i>	.60
60	0-051-206-01	<i>Power Transformer Shield Plate</i>	.40
	0-051-380-02	<i>Screw for Selector Cam</i>	.10
103	0-027-119-04	<i>Take-up Reel Table Shaft</i>	.25
104	0-027-120-02	<i>Supply Reel Table Shaft</i>	.25
114	0-027-201-01	<i>Reset Spring for Fast Forward Cam</i>	.10
122	0-027-479-01	<i>Pinch Roller Oil Ring</i>	.05
	0-037-248-01	<i>Washer for Speed Selector</i>	.10
	0-007-239-01	<i>Spring for Tube Holding</i>	.05